



# Photography

## Merit Badge Workbook

This workbook can help you but you still need to read the merit badge pamphlet.

The work space provided for each requirement should be used by the Scout to make notes for discussing the item with his counselor, not for providing the full and complete answers. Each Scout must do each requirement.

No one may add or subtract from the official requirements found in **Boy Scout Requirements** (Pub. 33216 – SKU 34765).

The requirements were last issued or revised in 2006 • This workbook was updated in January 2013.

Scout's Name: \_\_\_\_\_ Unit: \_\_\_\_\_

Counselor's Name: \_\_\_\_\_ Counselor's Phone No.: \_\_\_\_\_

<http://www.USScouts.Org> • <http://www.MeritBadge.Org>

Please submit errors, omissions, comments or suggestions about this **workbook** to: [Workbooks@USScouts.Org](mailto:Workbooks@USScouts.Org)  
Comments or suggestions for changes to the **requirements** for the **merit badge** should be sent to: [Merit.Badge@Scouting.Org](mailto:Merit.Badge@Scouting.Org)

1. Explain how the following elements and terms affect the quality of a picture:

a. Light-natural light/ambient, flash

Natural light/ambient: \_\_\_\_\_  
\_\_\_\_\_  
\_\_\_\_\_

Flash: \_\_\_\_\_  
\_\_\_\_\_

b. Exposure-aperture (f-stops), shutter speed, depth of field

Aperture (f-stops): \_\_\_\_\_  
\_\_\_\_\_  
\_\_\_\_\_

Shutter speed: \_\_\_\_\_  
\_\_\_\_\_

Depth of field: \_\_\_\_\_  
\_\_\_\_\_

c. Composition-rule of thirds, leading lines, framing, depth

Rule of thirds: \_\_\_\_\_  
\_\_\_\_\_

Leading lines: \_\_\_\_\_  
\_\_\_\_\_

Framing: \_\_\_\_\_  
\_\_\_\_\_

Depth: \_\_\_\_\_  
\_\_\_\_\_

d. Angle of view \_\_\_\_\_

e. Stopping action \_\_\_\_\_

2. Explain the basic parts and operation of a film camera or digital camera \_\_\_\_\_

---

---

---

---

---

---

---

---

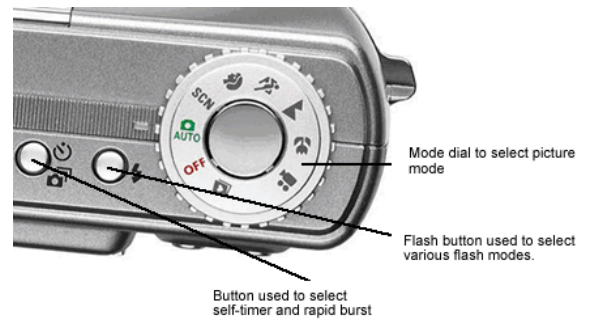
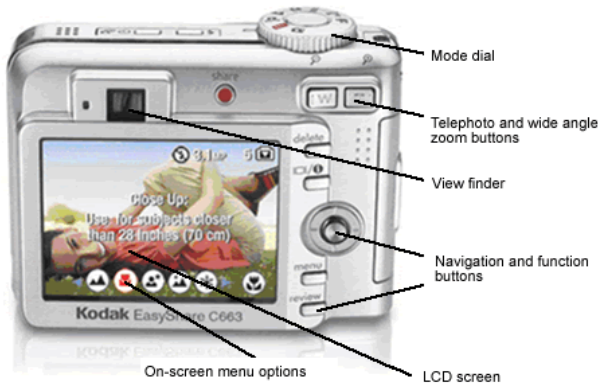
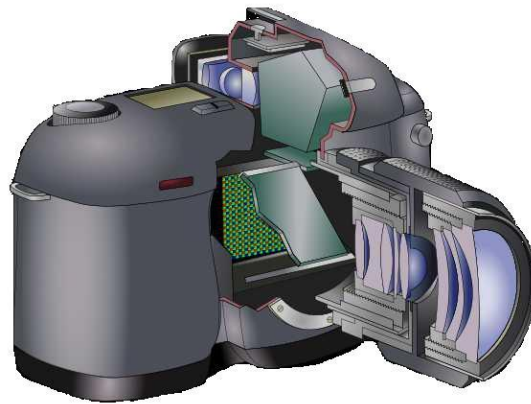

Explain how an exposure is made when you take a picture. \_\_\_\_\_

---

---

---

3. Discuss with your counselor the differences between a film camera and a digital camera. \_\_\_\_\_

\_\_\_\_\_

\_\_\_\_\_

List at least five advantages and five disadvantages of using a digital camera versus using a film camera.

Advantages:

1. \_\_\_\_\_
2. \_\_\_\_\_
3. \_\_\_\_\_
4. \_\_\_\_\_
5. \_\_\_\_\_

Disadvantages:

1. \_\_\_\_\_
2. \_\_\_\_\_
3. \_\_\_\_\_
4. \_\_\_\_\_
5. \_\_\_\_\_

4. Do ONE of the following:

- a. Produce a picture story using the photojournalistic technique of documenting an event. Share your plan with your counselor and get your counselor's input and approval before you proceed. Then, using either a film camera or a digital camera, produce your approved picture story. Process your images and select eight to 12 images that best tell your story. Arrange your images in order, then mount the prints on a poster board. If you are using digital images, you may create a slide show on your computer or produce printouts for your poster board. Share your picture story with your counselor.
- b. Choose a topic that interests you to photograph for an exhibit or display. Get your counselor's approval, then photograph (digital or film) your topic. Process your images. Choose 20 of your favorite images and mount them on poster board. Share your display with your counselor. If you are using digital images, you may create a slide show on your computer or produce printouts for your poster board.

\_\_\_\_\_

\_\_\_\_\_

\_\_\_\_\_

\_\_\_\_\_

\_\_\_\_\_

\_\_\_\_\_

\_\_\_\_\_

\_\_\_\_\_

\_\_\_\_\_

5. Discuss with your counselor the career opportunities in photography. \_\_\_\_\_

---

---

---

---

---

---

---

Pick one that interests you and explain how to prepare for such a career \_\_\_\_\_

Discuss with your counselor the education and training such a career would require. \_\_\_\_\_

---

---

---

---

---

---

---

**Requirement resources can be found here:**  
[http://www.meritbadge.org/wiki/index.php/Photography#Requirement\\_resources](http://www.meritbadge.org/wiki/index.php/Photography#Requirement_resources)

## Important excerpts from the [‘Guide To Advancement’](#), No. 33088:

Effective January 1, 2012, the *‘Guide to Advancement’* (which replaced the publication *‘Advancement Committee Policies and Procedures’*) is now the *official* Boy Scouts of America source on advancement policies and procedures.

- **[ Inside front cover, and 5.0.1.4 ] — Unauthorized Changes to Advancement Program**  
***No council, committee, district, unit, or individual has the authority to add to, or subtract from, advancement requirements.***  
(There are limited exceptions relating only to youth members with disabilities. For details see section 10, “Advancement for Members With Special Needs”.)
- **[ Inside front cover, and 7.0.1.1 ] — The [‘Guide to Safe Scouting’](#) Applies**  
Policies and procedures outlined in the *‘Guide to Safe Scouting’*, No. 34416, apply to all BSA activities, including those related to advancement and Eagle Scout service projects. [Note: Always reference the online version, which is updated quarterly.]
- **[ 7.0.3.1 ] — The Buddy System and Certifying Completion**  
Youth members must not meet one-on-one with adults. Sessions with counselors must take place where others can view the interaction, or the Scout must have a buddy: a friend, parent, guardian, brother, sister, or other relative —or better yet, another Scout working on the same badge— along with him attending the session. When the Scout meets with the counselor, he should bring any required projects. If these cannot be transported, he should present evidence, such as photographs or adult certification. His unit leader, for example, might state that a satisfactory bridge or tower has been built for the Pioneering merit badge, or that meals were prepared for Cooking. If there are questions that requirements were met, a counselor may confirm with adults involved. Once satisfied, the counselor signs the blue card using the date upon which the Scout completed the requirements, or in the case of partials, initials the individual requirements passed.
- **[ 7.0.3.2 ] — Group Instruction**  
It is acceptable—and sometimes desirable—for merit badges to be taught in group settings. This often occurs at camp and merit badge midways or similar events. Interactive group discussions can support learning. The method can also be attractive to “guest experts” assisting registered and approved counselors. Slide shows, skits, demonstrations, panels, and various other techniques can also be employed, but as any teacher can attest, not everyone will learn all the material.

There must be attention to each individual’s projects and his fulfillment of *all* requirements. We must know that every Scout — actually and *personally*— completed them. If, for example, a requirement uses words like “show,” “demonstrate,” or “discuss,” then every Scout must do that. It is unacceptable to award badges on the basis of sitting in classrooms *watching* demonstrations, or remaining silent during discussions. Because of the importance of individual attention in the merit badge plan, group instruction should be limited to those scenarios where the benefits are compelling.

- **[ 7.0.3.3 ] — Partial Completions**  
Scouts need not pass all requirements with one counselor. The Application for Merit Badge has a place to record what has been finished — a “partial.” In the center section on the reverse of the blue card, the counselor initials for each requirement passed. In the case of a partial completion, he or she does not retain the counselor’s portion of the card. A subsequent counselor may choose not to accept partial work, but this should be rare. A Scout, if he believes he is being treated unfairly, may work with his Scoutmaster to find another counselor. An example for the use of a signed partial would be to take it to camp as proof of prerequisites. Partials have no expiration except the 18th birthday.