



# BALOO'S BUGLE



Volume 11, Number 9

April Cub Scout Roundtable

May Cub Scout Theme

## PET PALS

Tiger Cub Activities

Webelos Outdoorsman & Handyman

### FOCUS

*Cub Scout Roundtable Leaders' Guide*

Pets can be wonderful companions. This month boys will learn about pets and how to care for them. They will see what it takes to be good pet owners and, also, learn about the responsibilities involved. Since 1915, every May the American Humane Association celebrates "Be kind to Animals Week." to help teach people to be compassionate toward animals.

### CORE VALUES

*Cub Scout Roundtable Leaders' Guide*

Some of the purposes of Cub Scouting developed through this month's theme are:

- ✓ **Character Development**, Boys will learn that caring for a pet requires patience and an attitude of selfless giving.
- ✓ **Spiritual Growth**, caring for pets will help boys better appreciate the value of all life.
- ✓ **Respectful Relationships**, Boys will learn about the interdependence in all our relationships and our duty to speak for those who don't have a voice.

The core value highlighted this month is:

- ✓ **Responsibility**, Boys will learn first hand the tasks involved in caring for a pet.

Can you think of others??? Hint – look in your **Cub Scout Program Helps**. It lists different ones!! All the items on both lists are applicable!! You could probably list all twelve if you thought about it!!

### Update on status of [www.USScouts.org](http://www.USScouts.org)

#### Donations are still needed -

To be able to continue we will need more donations to help us through this tight spot. Donations are accepted via PayPal™ by using the following email address:

[donate2usscouts.org@verizon.net](mailto:donate2usscouts.org@verizon.net)

The U.S. Scouting Service Project, Inc., started in 1994, is a non-profit organization that makes available to the Internet community additional information, resources and reference material concerning the Scouting programs carried out through the Boy Scouts of America. It is not funded nor supported by the Boy

Scouts of America. All members of the Project serve as volunteers to plan, create, develop, post, maintain and enhance a family of websites and web resources as well as to promote the responsible usage of the Internet and its capabilities. This is in addition to their daily work, family and community, and Scouting obligations. The Service Project is always looking for additional hands to "share the fun of another one night a week" of Scouting and additional ways that we can leverage the potentials of the Internet and in particular the World Wide Web against the needs of the volunteer, professional, families and their youth involved in the programs of the Boy Scouts of America.

### COMMISSIONER'S CORNER

This has been an up and down month – Wood Badge (always two words) staff development began. And I got in trouble right away. We had great a Waterways Roundtable with an excited presenter on our local tall ship – The Kalmar Nyckel ([www.kalmarnyckel.org](http://www.kalmarnyckel.org)). After talking with the Cub leaders, she went over to the Boy Scout and Venturing RTs and got them excited, too. Bill Smith of Bill Smith's Unofficial Roundtable ([www.wtsmith.com/rt](http://www.wtsmith.com/rt)) and host of the temporary home for Baloo while the USScouts.org's server was down, offered to write the monthly Training Tip for Baloo. Wow! In case you are wondering what makes him a great Scouter, part of it has to be he started in New Jersey!!!

My nephew in Lovettsville, VA, crosses over from Webelos to Boy Scouts in April after earning his Arrow of Light and helping in a flag ceremony with a military color guard. I hope to be there.

From a Snapple lid I saw this month – What is the only country with a National Dog? Great Dane for Denmark – NO, French Poodle for France – NO, German Shepherd for Germany – NO, Irish Setter for Ireland – NO, English Bulldog for England – NO, Aikido for Japan – NO, Labrador Retriever or Newfoundland for Canada – NO, Australian Cattle Dog for Australia – NO. Well which one? **The National Dog of Holland is the Keeshond.** It was chosen because they were used as watchdogs riding the canal barges!!

Some big news for Pinewood Derby – In March there was an article in the Wall Street Journal on Pinewood Derbies. It

was still available on line at [www.wsj.com](http://www.wsj.com) when last I looked. Search for "Driving under the influence - of Dad."

And Hollywood is about to release a movie, "Down and Derby" about Pinewood Derbies. Check it out at <http://www.downandderby.com/home.php>. Limited release is April 15. If it does well enough, full release will be Father's Day. Don Murphy who created the first Pinewood Derby in 1953 has a cameo in the movie!!

**Months with similar themes to  
Pet Pals**

*Voyageur Area Council*  
February 2001.....Man's Best Friend

*I did check my Excel list of past themes and yes, Pets, has only been done once before. CD*

**THOUGHTFUL ITEMS FOR  
SCOUTERS**

**May Theme Prayer**

*Cub Scout Roundtable Leaders' Guide*

Chief Seattle said, "What is man without the beasts? If all the beasts are gone, man would die from great loneliness of spirit. For whatever happens to the beasts soon happens to man. All things are connected. AMEN

*Santa Clara County Council*

Quotations contain the wisdom of the ages, and are a great source of inspiration for Cubmaster's minutes, material for an advancement ceremony or an insightful addition to a Pack Meeting program cover.

"An animal has been made by God, just as you have been. He is therefore a fellow-creature." – **Lord Robert Baden-Powell**

"A boy can learn a lot from a dog: obedience, loyalty, and the importance of turning around three times before lying down." – **Robert Benchley (1889 - 1945)**

"If a dog jumps in your lap, it is because he is fond of you; but if a cat does the same thing, it is because your lap is warmer." – **Alfred North Whitehead (1861 - 1947)**

"I like pigs. Dogs look up to us. Cats look down on us. Pigs treat us as equals". **Sir Winston Churchill (1874 - 1965)**

"It's funny how dogs and cats know the inside of folks better than other folks do, isn't it?" – **Eleanor H. Porter (1868 - 1920), Pollyanna, 1912**

"If you are a dog and your owner suggests that you wear a sweater, suggest that he wear a tail." – **Fran Lebowitz (1950 - )**

"We call them dumb animals, and so they are, for they cannot tell us how they feel, but they do not suffer less because they have no words." - **Anna Sewell (1820 - 1878), Black Beauty, 1877**

"Outside of a dog, a book is probably man's best friend; inside of a dog, it's too dark to read." – **Groucho Marx**

**Life Lessons Learned from a Dog:**

*Santa Clara County Council*

- ✓ If you stare at someone long enough, eventually you'll get what you want.
- ✓ Don't go out without ID.

- ✓ Be aware of when to hold your tongue, and when to use it.
- ✓ Leave room in your schedule for a good nap.
- ✓ Always give people a friendly greeting.
- ✓ When you do something wrong, always take responsibility (as soon as you're dragged shamefully out from under the bed).
- ✓ If it's not wet and sloppy, it's not a real kiss.

**SCCC suggests this as a Cubmaster's Closing Minute CD**

**Dogs as Teachers**

*Santa Clara County Council*

If a dog were your teacher you'd learn stuff like:

- ✓ When loved ones come home, always run to greet them.
- ✓ Never pass up the opportunity to go for a joyride.
- ✓ Allow the experience of fresh air and the wind in your face to be pure ecstasy.
- ✓ When it's in your best interest--practice obedience.
- ✓ Let others know when they've invaded your territory.
- ✓ Take naps and stretch before rising.
- ✓ Run, romp, and play daily.
- ✓ Avoid biting when a simple growl will do.
- ✓ On warm days, stop to lie on your back on the grass.
- ✓ On hot days, drink lots of water and flop under a shady tree.
- ✓ When you're happy, dance around and wag your entire body.
- ✓ Delight in the simple joy of a long walk.
- ✓ Eat with gusto and enthusiasm. Stop when you have had enough.
- ✓ Be loyal.
- ✓ Never pretend to be something you're not.
- ✓ If what you want lies buried, dig until you find it.
- ✓ When someone is having a bad day, be silent, sit close by and nuzzle them gently.

**I Wish My Daddy Was a Dog**

*Baltimore Area Council*

One day when my son was just a lad starting out in school  
He came into my workshop and climbed upon a stool  
I saw him as he entered but I hadn't time to play.  
So I merely nodded to him and said "Don't get in the way".

He sat a while just thinking--as quiet as could be.  
Then carefully he got down and came and stood by me.  
He said "Old Shep, he never works and he has lots of fun.  
He runs around the meadows and barks up at the sun."

"He chases after rabbits and always scares the cats.  
He likes to chew on old shoes, and mother doesn't like that.  
But when we're tired of running we sit down on a log,  
I sometimes get to thinking I wish my Daddy was a dog.  
Cause then when I came home from school he'd run and lick  
my hand.

And we would jump and holler and tumble in the sand.  
And then I'd be as happy, as happy as could be.  
Cause we would play the whole day through just my Dad  
and me.

“Now I know you work real hard to buy us food and clothes.  
And you need to get the girls those fancy ribbons and bows.  
But sometimes when I’m lonesome I think it would be lots  
of fun

If My Daddy Was a Dog and all his work was done.”

Now when he’d finished speaking he looked so lonely there,  
I reached my hand out to him and ruffled up his hair.  
And as I turned my head aside to brush away a tear,  
I thought how nice it was to have my son so near.

I know the Lord didn’t mean for man to toil his whole life  
through,

“Come on my son, I’m sure I have some time for you.”  
You should have seen the joy and sunlight in his eye.  
As we went outside to play -- Just my son and I.

Now, as the years have flown and youth has slipped away,  
I’ve tried always to remember to allow some time to play.

When I pause to reminisce and think of joys and strife,  
I carefully turn the pages of this wondrous book of life

I find the richest entry recorded in this daily log  
Is the day that small boy whispered, “I wish my Daddy was  
a dog”.

## TRAINING TIP

### Parents

*Bill Smith, The Roundtable Guy*

A special welcome to Bill Smith who will be preparing the  
Training Tip each month. Be sure to visit his website,  
[www.wtsmith.com/rt](http://www.wtsmith.com/rt)

Check out the many good Scouting ideas he has and Thank  
him for offering a temporary home to Baloo while  
[www.usscouts.org](http://www.usscouts.org) was shut down and now helping each  
month with Training Tips.

### A Home and Neighborhood Program

The Cub Scout program of the Boy Scouts of America is  
unique among the various Cub programs in the World  
Scouting movement. Our method is based on activities a boy  
could do around his own home or in his immediate  
neighborhood. While most other Cub organizations  
conducted a sort of “junior Boy Scout” program with a few  
leaders in each pack, the BSA opts for something quite  
different: fun stuff right near home with adult leaders for  
each den.

The life of a six-to-ten year old is centered on his home. He  
is just learning how to form close friends and explore new  
places. He still looks to mom and dad for approval, support  
and advice. Typically, he doesn’t start reaching out to other  
adults away from his home until the middle school years.  
Those Cub Scout years are recognized as an opportunity  
window for parents to exercise the greatest influence on their  
sons. Fathers who wait until their sons are in Boy Scouts to  
become involved are often rudely disappointed – by then,  
the boys are usually looking elsewhere for guidance and  
inspiration. Do it now in Cub Scouting!

### The Parent Agreement

When families join your pack, each parent should be  
introduced to the Parent’s Agreement on the second page of  
the boy’s Application to Join. Each leader should be familiar

with this agreement and be prepared to help parents  
understand its implications and their responsibilities.

### Being at Meetings

Younger Cub Scouts, and especially Tigers, are much more  
comfortable having a parent with them at meetings and  
activities. Pack meetings are where the boys get a chance to  
show off – where they are recognized for Doing Their Best,  
for living up to all those ideals in the Cub Scout Promise and  
Motto. It’s important those adults who love him are there to  
share in this recognition and be part of the celebration.

One of the huge benefits of Cub Scouting is that parents are  
forced to meet and communicate with other neighborhood  
parents which puts you one good step ahead as your boy  
enters his teen years. You know and talk to his friends  
parents.

### Working in the Books

The achievements - 15 Tiger, 12 Wolf and 12 Bear -  
represent those things a growing boy should be doing as he  
learns to be a better citizen and a more responsible and  
capable human being. They give parents and others ample  
opportunities to observe and understand how this boy is  
growing up: what sort of adult he will be, what kind of  
husband, what type of father, and what quality of community  
member he will become. Informed parents and leaders can -  
and should - make the achievements fun experiences for the  
boys.

But there is a lot more to it. The electives automatically  
involve TALKING. The boy and his parent TALK, they  
listen to each other, they plan; they express their hopes, their  
concerns, and their jokes. They learn to respect each others  
moods, ideas and styles. They create special communication  
channels that remain vital and valuable for all their lives.

If you, as a leader, shut out the parents by doing a lot of  
Tiger and Cub Scout advancement at den meetings then you  
deny the parents the opportunity to establish these  
relationships with their sons.

### Helping Leaders

Cub Scouting gives parents opportunities to show their sons  
examples of leadership and responsibility. It may be a  
leading a den or pack meeting, or organizing the Blue &  
Gold banquet or Fourth of July Parade or Friends of  
Scouting campaign, but every parent should take on a visible  
job in his Cub Scout pack where the Cub Scout can see his  
role model doing something important.

### How to Involve Parents

**It takes constant effort, patience and a sense of humor!!**

### When the Boy Joins

Ensure that every family is aware of the Parent’s Agreement  
and understands their obligations when we accept their  
application to join. The longer we wait the harder it becomes  
to involve parents. Recruit the parent along with the boy.

### Organization and Support

One of the most important tasks a Cub Scout leader does is  
to convince other parents how important it is for them to get  
involved in their sons' Cub Scout program and how this  
helps their families and their boys' development. When they

make that a priority and then start working at it, they have a good chance at success.

Being a good Cub Scout leader takes more than just running the meetings - that's the easy part. Interacting with other adults - especially parents - is the essential job quality of Cub Scout leadership.

Each time we take on another job that could be done by a parent who is not performing as a role model for his/her son we are admitting that we have failed. Instead of sharing responsibility we have opted for the easy work around: do it ourselves instead of teaching others that it is better that they do it.

Worse, we have hurt two boys. We have hurt our own sons because the time it takes to do the second (or third and so on) job often comes from the time needed to fulfill our duties as Akela to our own sons, and also, we have deprived another boy the chance to see his parent be a hero - doing something important in his Cub pack.

Never, never do anything that you can possibly get another parent to do.

## PACK ADMIN HELPS

*I ran this last one last month but because USScouts.org was not fully up, I thought I would run it again CD*  
**Cub Scout Achievement, Elective, Rank, and Academics and Sports Trackers**

*Roxanne@madsenco.com*

A lot of websites carry the Excel based trackers she developed but have old and outdated versions. So Roxanne developed her own web page that will always carry the most recent versions (with all known bugs fixed and many enhancements recommended by users).

She recently revised the Cub Scout spreadsheets to –

- ✓ Include the Outdoor Activity Award that was launched in August 2004!
- ✓ Make them easier to work with in OpenOffice.
- ✓ Track Tiger beads and handle up to 15 tigers.

Please direct your den leaders or advancement chairs to the website for the most recent versions of the trackers. (feel free to add a link to your pack's website if that is helpful!)

<http://www.madsenco.com/scouting.shtml>

*Thank you Roxanne!! CD*

*PS – She, also, has Girl Scout and Boy Scout Trackers!!!*

**Keeping the Doors Open:  
 Pack Fundraisers and Finance**  
*Santa Clara County Council*

### Unit Money-Earning Project Guidelines

The unit leadership in chartered organizations may participate in approved fund-raising projects, provided the Rules and Regulations and guidelines of the Boy Scouts of America are followed to ensure the quality of the product or service, to ensure the safety of all participants, and to avoid the commercialization of the Boy Scouts of America. Every unit conducting such an activity must submit a Unit Money-Earning Application, No.34427, for advance approval by the chartered organization and the local council at least thirty days before the activity.

Whenever your unit is planning a money-earning project, the following checklist can serve as your guide. If you can answer yes to each of the following questions, it is likely that your project will be approved.

1. Has your unit committee and chartered organization approved your project, including the dates and the methods?  
*There should be a real need for earning money based on your unit's program. We should not engage in special money-earning projects merely because someone has offered us an attractive plan. It's important to remember that individual youth members are also expected to earn their own way. The need should be over and above normal budget items covered by dues.*
2. Does your plan and corresponding dates avoid competition with money-raising efforts and policies of other units, your chartered organization, your local council, and the United Way?  
*Check with your chartered organization representative to make certain that your chartered organization agrees on the dates. The chartered organization representative can also clear the other dates by calling the council service center.*
3. Does your plan comply with local ordinances; is it free from any association with gambling; and is it consistent with the ideals and purposes of the Boy Scouts of America Money-raising projects that include the sale of raffle tickets are in violation of this policy.  
*This includes any activity where value is not guaranteed by purchasing a ticket. (For example, cake raffles would no be allowed, but cake auctions are okay.) This question can be answered only in terms of specific proposals. If there is any question of its suitability, drop the project and find a better one for your unit.*
4. If a commercial product is to be sold, will it be sold on its own merits and without reference to the needs of Scouting, either directly (during sales presentation) or indirectly?  
*Teaching youth members to become self-reliant and to earn their own way is an important part of training our youth members. The official uniform is intended to be worn primarily for use in connection with Scouting activities. However, the executive board of the local council may authorize wearing the uniform in connection with council-sponsored product sales programs.*
5. If tickets are sold for a function other than a Scouting event, will they be sold by your youth members as individuals without depending on the goodwill of Scouting to make this sale possible?  
*Youth members in uniform in the name of Scouting may sell tickets for such things as pack shows, troop suppers, circuses, expositions, and similar Scouting events.*
6. Even when sales are confined to parents and friends, will buyers get their money's worth from any product they purchase, function they attend, or services they receive from your unit?  
*Here again is the principle of value received - a sale*

*standing on its own merit - so that the recipients are not in any way subsidizing either Scouting or the member. Youth members must learn to pay their own way and to honestly earn the money to do it. You cannot permit anyone to use the good name of Scouting to sell a product.*

7. If a project is planned for a particular area, do you respect the right of other Scouting units in the same neighborhood?  
*It's a courtesy to check with neighboring units or the local council service center to coordinate the time of your project and to see that your aren't covering their territory. Your unit commissioner or service team member can help you with this.*
8. Is it reasonably certain that people who need work or business will not lose it as a result of your unit's plan.  
*Your unit should neither sell nor offer services that will damage someone's livelihood. If possible, check with the people who could be affected.*
9. Will your plan protect the name and goodwill of the Boy Scouts of America and prevent it from being capitalized on by promoters of shows, benefits, or sales campaigns?  
*Because of Scouting's good reputation, customers rarely question the quality or price of a product. Unchecked, the network of Scouting units could become a beehive of commercial interest to the neglect of character building and citizenship training.*
10. If any contracts are to be signed by your unit, will they be signed by an individual without reference to the Boy Scouts of America, and in no way appear to bind the local council, the Boy Scouts of America, or the chartered organization to any agreement of financial responsibility?  
*Before any person in your unit signs a contract, he or she must make sure the venture is legitimate and worthy. If a contract is signed, he or she is personally responsible. A contract cannot be signed on behalf of the local council or the Boy Scouts of America, nor may an individual bind the chartered organization without its written authorization. If you are not sure, check with your local council service center for help.*

**Current Policies of the Boy Scouts of America Contributions**

*Bylaws of the Boy Scouts of America, Article XI, Section 1, Clause 2:*

Contributions shall be solicited in the name of the Boy Scouts of America only through or by the authority of the Corporation, and shall be limited to the National Council or chartered local councils, in accordance with these Bylaws and Rules and Regulations of the Corporation. Youth members shall not be permitted to serve as solicitors of money for chartered organization units, for the local council, or in support of other organizations. Adult members and youth members shall not be permitted to serve as solicitors of money in support of personal or unit participation in local, national or international events. Youth members, however, are permitted to secure sponsors for council or district activities approved by the executive board. These approved

activities may result in financial support for the local council in accordance with the Bylaws and Rules and Regulations of the Corporation.

**Use of the Uniform**

*Rules and Regulations of the Boy Scouts of America, Article X, Section 4, Clause 6:*

The official uniforms are intended primarily for use in connection with Scouting activities as defined by the national Executive Board and their use may be approved by local council executive board for council events or activities under conditions consistent with the Rules and Regulations of the Boy Scouts of America.

**Gambling**

*Rules and Regulations of the Boy Scouts of America, Article XI, Section 1, Clause 1:*

Gambling. Any fund-raising project designated to benefit chartered organization units, districts, local council, or on a national basis which involves games of chance, lotteries, sale of raffle tickets, bingo, or could be construed as a gambling activity, is not permitted.

**Unit Money-Earning Projects**

*Rules and Regulations of the Boy Scouts of America, article IX, section 2, clause 3:*

Units may conduct money-earning projects only when the projects have been approved by the chartered organization and the local council and are consistent with the principles set forth in these Rules and Regulations.

**Tax-Exempt Status Of Units and Contributions To Units**

The basic issues regarding the tax-exempt status of Cub Scout Packs, Boy Scout Troops, Explorer units, and even Tiger Cub or Cub Scout Dens are addressed in the basic concept of the charter process employed by the Boy Scouts of America reduced to the simplest terms as follows:

1. The local council recommends that specific organizations receive a charter from the national office based on specific requirements and guidelines.
2. These organizations vary from schools, religious organizations, civic clubs, neighborhood groups, business, industry, and others; each with a different tax status. While some may be tax exempt under IRS Code section 501 (c)(3), others may not be tax-exempt.

**Important:** The tax-exempt status of the chartered organization determines the tax-exempt status of their units - pack, troop, post, etc. The national office (National Council) maintains the group exemption status for the local incorporated Boy Scout councils and the local council trust funds conforming to the Model Form Trust Agreement.

Annually, the employer identification numbers of the local council and local council trust funds are forwarded to the Internal Revenue Service in order to maintain the group exemption status of these designated subordinates receiving a charter from the national office.

The chartered organizations with tax-exempt status maintain their status independently from the National Council and local council. Their units' tax-exempt status will be consistent with the tax exempt status of the chartered organization.

## TIGERS

By now your Tigers have probably earned their Tiger Badges and are anxious to move on up. Two projects you may want to work on this Spring are

- ✓ Earning the Leave No Trace Award at the Tiger Level
- ✓ Earning their Bobcat before Summer.

If your Pack has an active Outdoor Program with two camping trips and several other outdoor activities your Tigers may be well on their way to earning the Leave No Trace Award. The requirements are in the back of their Tiger books.

**BUT MORE IMPORTANTLY** – Have them complete their Bobcat Requirements before promotion to Wolves. Then they will have their books (My pack presents books for the next rank in our graduation ceremony) and can start the Family Activities this summer while out of school and (hopefully) taking some sort of vacation with their parent(s) or other family. This will, also, help your life as a leader easier in the Fall when you (hopefully) get new Scouts who have to earn their Bobcat right away.

Have the Cubmaster Challenge the Tigers in one Pack Meeting to return next month as new Bobcats. One of my “Den and Pack Ceremonies” books has the Zulu Challenge, which I have used often for this purpose.

Don’t just tell the boys to memorize the stuff, play games with it. Have flash cards for parts of the Promise and Law and have the boys place them in correct order. Have them draw posters of what the words mean to them. BSA used to have a comic book publication – “A Cub Scout Action Book – Bobcat” with lots of games and activities to help boys learn the Bobcat requirements. Maybe you can find a copy in your Pack Library. Check the requirements to make sure they are still current. Remember – WEBELOS is “WE’ll BE Loyal Scouts” not “Wolf, Bear, Lion, Scout” as it says in my 1957 book.

## SPECIAL OPPORTUNITY

**New! Cub Scout Outdoor Activity Award**

*Kommissioner Karl*



Tiger Cubs, Wolf and Bear Cub Scouts, and Webelos Scouts have the opportunity to earn the Cub Scout Outdoor Activity Award. Boys may earn the award in each of the program years as long as the requirements are completed each year. The first time the award is earned, the boy will receive the pocket flap award, which is to be worn on the right pocket flap of the uniform shirt.

Each successive time the award is earned, a wolf track pin may be added to the flap. Leaders should encourage boys to build on skills and experiences from previous years when working on the award for a successive year.

### Requirements

#### All Ranks

Attend Cub Scout day camp or Cub Scout/Webelos Scout resident camp. (To be completed after September 1, 2004. Award was launched in late August 2004)

#### Rank-Specific

##### Tiger Cubs

Complete one requirement in Achievement 5, "Let's Go Outdoors" (Tiger Cub Handbook) and complete three of the outdoor activities listed below.

##### Wolf Cub Scouts

Assemble the "Six Essentials for Going Outdoors" (Wolf Handbook, Elective 23b) and discuss their purpose, and complete four of the outdoor activities listed below.

##### Bear Cub Scouts

Earn the Cub Scout Leave No Trace Award (Bear Handbook, Elective 25h) and complete five of the outdoor activities listed below.

##### Webelos Scouts

Earn the Outdoorsman Activity Badge (Webelos Handbook) and complete six of the outdoor activities listed below.

##### Outdoor Activities

With your den, pack, or family:

1. Participate in a nature hike in your local area. This can be on an organized, marked trail, or just a hike to observe nature in your area.
2. Participate in an outdoor activity such as a picnic or park fun day.
3. Explain the buddy system and tell what to do if lost. Explain the importance of cooperation.
4. Attend a pack overnighiter. Be responsible by being prepared for the event.
5. Complete an outdoor service project in your community.
6. Complete a nature/conservation project in your area. This project should involve improving, beautifying, or supporting natural habitats. Discuss how this project helped you to respect nature.
7. Earn the Summertime Pack Award.
8. Participate in a nature observation activity. Describe or illustrate and display your observations at a den or pack meeting.
9. Participate in an outdoor aquatic activity. This can be an organized swim meet or just a den or pack swim.
10. Participate in an outdoor campfire program. Perform in a skit, sing a song, or take part in a ceremony.
11. Participate in an outdoor sporting event.
12. Participate in an outdoor Scout's Own or other worship service.
13. Explore a local city, county, state, or national park. Discuss with your den how a good citizen obeys the park rules.



**Cub Scouter Training Award**  
*Kommissioner Karl*



The Cub Scouter Award is available to all registered adult leaders in the Pack, including committee members. The requirements focus on building a better or more effective Pack program. You must complete two years a registered Scouter, fast start, basic and specific training for any position, and be current with Youth Protection Training. In addition, you must complete 5 of 10 options for providing leadership to the pack, via planning special events, training, promoting program basics or assisting program ideas for other leaders. For a downloadable progress record and to see these options, go to:

<http://www.scouting.org/forms/34169/54.pdf>

Chances are, if you are working as a den leader in your Pack; you will complete these requirements over the two years that you are not earning your Den Leader and Webelos Leader awards. You may have Pack Committee members that have done this as well, so get them to training and get them their recognition!

**GATHERING ACTIVITIES**

**Pets in Spanish**

*Santa Clara County Council*

Label the pets below with their Spanish names:

- 1) el perro                      2) el carpa dorada                      3) el gato
- 4) el periquito                      5) el potro                      6) la tortuga
- 7) el loro                      8) la marmota

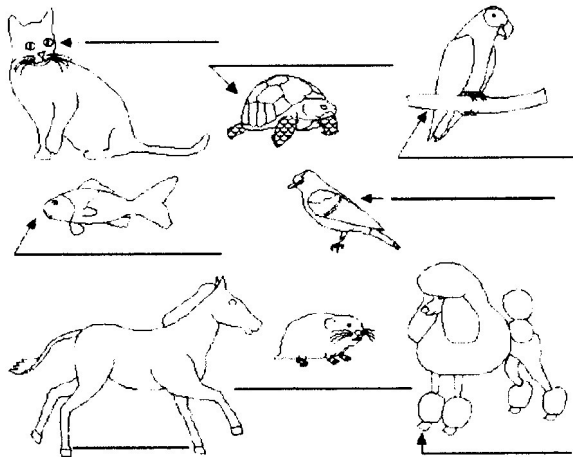

**Answers:**

- Cat: el gato                      Turtle: la tortuga                      Parrot: el loro
- Goldfish: el carpa dorada                      Parakeet: el periquito
- Pony: el potro                      Hamster: la marmota                      Dog: el perro

**A Dog's Life Word Search**

*Santa Clara County Council*

Can you find the dogs hidden in the puzzle below? They may be horizontal, vertical or diagonal, forwards or backwards.

*Be sure to copy and enlarge before doing this puzzle. CD*



- |              |            |             |
|--------------|------------|-------------|
| AIREDALE     | ALSATIAN   | APPENZELLER |
| BASSET       | BEAGLE     | BEDLINGTON  |
| BLOODHOUND   | BORZOI     | BOXER       |
| BULLDOG      | CHIHUAHUA  | CHINOOK     |
| CHOW CHOW    | COLLIE     | CORGI       |
| DACHSHUND    | DALMATIAN  | DOBERMAN    |
| GREAT DANE   | GREYHOUND  | HUSKY       |
| JACK RUSSELL | LABRADOR   | LANDSEER    |
| MAGYAR       | MASTIFF    | PEKINGESE   |
| POINTER      | POMERANIAN | POODLE      |
| PUG          | ROTTWEILER | SAMOYED     |
| SANSHU       | SETTER     | SHEEPDOG    |
| SPANIEL      | TERRIER    | WHIPPET     |

**Animals and Their Babies**

*Piedmont Council*

Equipment: Copies of the game

Directions: Match the animal with its baby. (Answers are in parentheses)

- |           |                |
|-----------|----------------|
| 1. Hen    | A - Calf       |
| 2. Seal   | B - Chick      |
| 3. Frog   | C - Cub        |
| 4. Cat    | D - Cygnet     |
| 5. Dog    | E - Duckling   |
| 6. Deer   | F - Fawn       |
| 7. Mare   | G - Gosling    |
| 8. Sheep  | H - Kitten     |
| 9. Lion   | I - Lamb       |
| 10. Swan  | J- Philly/foal |
| 11. Whale | K - Puppy      |
| 12. Bear  | L - Tadpole    |
| 13. Goose |                |
| 14. Duck  |                |

1. Hen (B-Chick), 2. Seal (A-Calf), 3. Frog (L-Tadpole), 4. Cat (H-Kitten), 5. Dog (K-Puppy), 6. Deer (F-Fawn), 7. Mare (J-Philly/foal), 8. Sheep (I-Lamb), 9. Lion (C-Cub),

10. Swan (D-Cygnets), 11. Whale (A-Calf), 12. Bear (C-Cub), 13. Goose (G-Gosling), 14. Duck (E-Duckling)

**Animal Crossword**  
Baltimore Area Council

**Across**

1. My stripes are usually black and white.
3. I am a bear from China.
5. The \_\_\_ is a mammal that lives in the ocean.
7. I have the longest neck.
8. It looks like I wear a mask.
9. Some people think I am a bear, but I am not. I am a "marsupial" animal. That means I carry my baby in my pouch.
10. The Siberian \_\_\_ is the largest member of the cat family.
13. I say "meow"
14. The male \_\_\_ carries the babies, not the female.
16. I am also known as the American Bison.
17. I can be stubborn at times.
18. In Florida, you will see signs that read, "Do not feed the \_\_\_\_\_."

**Down**

2. This is short for rhinoceroses.
3. A flightless marine bird.
4. The African \_\_\_ is the largest land mammal.
5. We lived millions of years ago.
6. I am a reptile.
11. I am a primate. Did you know that you are a primate too?
12. Short for hippopotamus.
13. People drink my milk.
15. This is Billy Bear's favorite animal.
17. I am man's best friend.

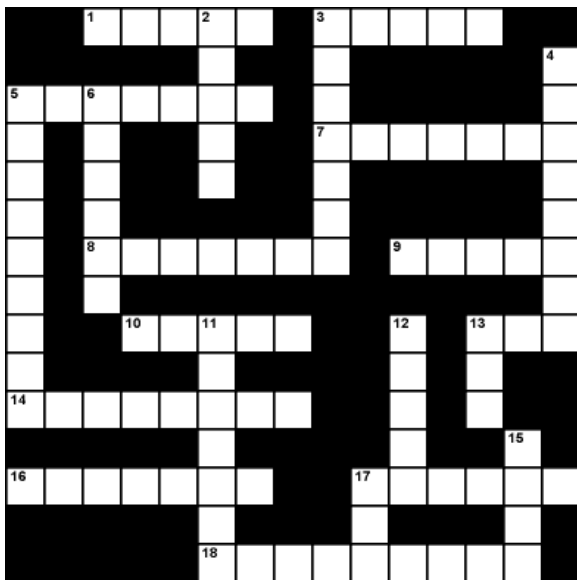

**OPENING CEREMONIES**

**MAN'S BEST FRIEND OPENING**  
Piedmont Council

**Arrangement:** Each Cub Scout holds a picture of the animal he is talking about. If desired, other animals can be added or substituted to make the ceremony more personal.

**Leader:** When you hear the term "man's best friend," you think of dogs. Tonight we'd like to tell you about some other of man's best friends.

**Cub # 1:** A cat can be a friend. My cat likes to curl up on my lap and purr. He likes to swat at his toy mouse and chase after a piece of string that I pull.

**Cub # 2:** A fish can be a friend. You might think that all a fish can do is swim around in his tank, but my fish makes me smile when he makes funny faces.

**Cub # 3:** A rabbit can be a friend. I like to watch my rabbit wrinkle up his nose, munch on carrots and hop around.

**Cub # 4:** Some of our animal friends are out of the ordinary. You could have a pet that is a slithery snake, or a little white mouse, or a high-hopping frog.

**Cub # 5:** Of course, we can't forget our friends the dogs. My dog is my friend because he loves to run and play with me. We both love to dig in the dirt and snooze in the shade. I always know he is happy to see me when he wags his tail.

**Leader:** Tonight, we will celebrate all kinds of pets. Let the festivities begin!

**Always Do Your Best**  
Baltimore Area Council

Prepare four cue cards, one for each Scout, with the following text on the back and the key word in large letters on the front. After reading each card, the Scout should hold his card up for everyone to see the key word.

**Cub # 1:** Key Word - "Always"  
When training a pet, a good Scout remembers to feed him and take care of him - Always (holds up his card).

**Cub # 2:** Key Word - "Do"  
Pets need company and someone to play with. Left alone, a pet becomes lonely and can become mean. Playing and spending time with a pet is the right thing to - Do (holds up second card).

**Cub # 3:** Key Word - "Your"  
When you have trained a pet, he learns to behave and to follow your instructions. When a pet does what you want him to do, you know that he is - Yours (holds up third card).

**Cub # 4:** Key Word - "Best"  
Pets often learn to greet you when you get home from school. Knowing that a pet likes to be with you is the - Best (holds up last card).

**Opening and Closing - Noah's Ark**  
Santa Clara County Council

**Props:** Make an ark out of a large sheet of cardboard set up so that the animals can enter and leave. Boys can also have pictures or stuffed animals of the animal they represent. Cubmaster or Den Leader playing Noah can be in a robe or other costume. He could also be holding a list to check off the animals as they arrive.



**Opening**

*Cubs enter two by two*

**1<sup>st</sup> Cubs:** We are the Tigers.

**Noah:** (checking list) Please enter. Take the last stall on the right. (Tigers enter)

**2nd Cubs:** We are the Bobcats.

**Noah:** Good to see you. You have the third stall on the left (Bobcats enter)

**3rd Cubs:** We are the Wolves.

**Noah:** Welcome. Second level, fifth stall on the left. (Wolves enter)

**4th Cubs:** We are the Bears.

**Noah:** Good. Come on in. Sixth stall on the left. (Bears enter). Now all the animals are aboard and we are ready to start. Let the Pack Meeting begin!

**During the Pack Meeting at spaced intervals Noah comes out to send the birds to find dry land. The last bird does not return which leads right into the closing**

**1st Interval,**

**Noah:** Fly away bird, find me dry land. (Pretends to send bird then waits a few moments) Oh, the bird returns. No dry land yet.

**2nd Interval**

**Noah:** Fly away bird, find me dry land. (Pretends to send bird. After a moment it returns) Oh, you have brought me a twig from a tree. Still too soon to land.

**Closing**

**Noah:** Fly away bird, find me dry land. (Sends bird, waits, bird does not return) Hooray, there is dry land. The ark is aground. Come animals, come out of the ark. It is time to start living on the ground again. (Animals come out of ark, stretching and scratching)

**Animals & Noah:** Ahh, look at the rainbow!

**Noah:** Thank you for joining us on our journey.

**All I Really Need To Know I Learned From My Dog**

*Baltimore Area Council*

*Actually, this could be an opening, closing or a series of run-ons. CD*

**Personnel:** Narrator and any number of Cubs.

**Setting:** Have lines on back of cards with pictures of dogs on the front. Follow readings with the Pledge of Allegiance. (Combine lines to accommodate the number Cubs.)

**Narrator:** All I really need to know I learned from my dog. Here are some examples.

Select the lines you wish to use. Use as many Cubs as you wish

- Allow the experience of fresh air and the wind in your face to be pure ecstasy.
- When loved ones come home, always run to greet them.
- Take naps and stretch before rising.
- Run, romp, and play daily.
- Be loyal.

- Never pretend to be something you're not.
- Eat with gusto and enthusiasm.
- If what you want lies buried, dig until you find it.
- When you leave your yard, make it an adventure.
- Bond with your Pack.
- On cold nights, curl up in front of a crackling fire.
- When you're excited, speak up.
- When you're happy, dance around and wag your entire body.
- Delight in the simple joy of a long walk.
- On hot days, drink lots of water and lay under a shady tree.
- Playtime is important.
- Every day can be an adventure.
- Sometimes a bark is worse than a bite.
- Too much of anything will make you sick.
- It's hard to stay mad at something cute.
- Looking adorable or pitiful can work in your favor.
- It's nice to be taken care of.
- Accidents happen.
- Play nicely with others and they'll play nicely with you.
- Stop and smell the roses, the dirt, the grass...

**PACK AND DEN ACTIVITIES**

**Pet Photo Frame**

*Santa Clara County Council*



**Supplies:**

Dog biscuits, kitty treats or other favors to represent the animal you will feature in the photo (for a bird, how about small seed bells, or other bird toys)

1 picture of your favorite animal

acrylic paint- any color

fine tipped marker

craft glue

paint brush- a small foam one will not leave brush marks

5X5 inch piece of cardboard or photo matting- *cereal boxes*

*work great*

craft knife

sealer- Design Master Super Surface Sealer, clear Sealer and Satin Finish 383 works great

ribbon or magnet

**Directions:**

1. Center your picture on top of cardboard and trace around it.
2. Use craft knife to cut out hole for picture.
3. Paint the front of the frame in the color of your choice.
4. Glue treats on to the frame.
5. On one of the treats or an open space on the frame write the animal's name, plus the dates of birth and death if they are now little angels.

6. Seal with sealer.
7. On the backside of the frame glue or tape the picture in place.
8. Add ribbon or magnet to the back to hang.

*Here is another way to make frames CD -*

**Fridge Frames**

*Baltimore Area Council*

Make a frame for your favorite pet photo and hang it on your fridge. Glue craft sticks together to form the frame. Let dry. Paint decoupage solution on dog biscuits, goldfish crackers, or animal crackers. Let dry. Glue to frame. You can make a birdseed frame by spreading the edge of the frame with glue and sprinkling on seeds. Let dry. Paint with decoupage solution. Stick 2 magnetic strips on the top and bottom of the back of the frame. Center the photo and use masking tape to attach it to the frame.

**VIRTUAL PET SHOW**

*Piedmont Council*

Instead of having a real pet show, boys bring drawings or photos of their pet (see Bear Elective 11). Set up an area in the room where the boys can display their "pets." People can go around the area looking at the virtual pets. Each boy stands next to his pet's photo and talks about his pet. They can also bring one or two of their pet's favorite toys, food, or maybe a taping of the pet's voice. Those boys who do not have pets may create imaginary ones (pet dinosaur? pet gorilla?) and have a showing with drawings and other paraphernalia.

**FIELD TRIP IDEAS**

*Piedmont Council*

- ✓ Zoos
- ✓ Veterinarians: Ask a vet if your den could visit
- ✓ Feed Shop
- ✓ Aquarium
- ✓ Pet supply shops: Find out if your den could visit

**GUEST SPEAKER**

*Piedmont Council*

- ✓ A veterinarian to come to your pack meeting and talk about the importance of caring for your pets properly.
- ✓ A Feed Shop owner to come and talk about animal nutrition
- ✓ A pet shop owner or manager
- ✓ A volunteer at the local SPCA or other animal shelter
- ✓ A county or city animal control officer
- ✓ Someone who raises show animals
- ✓ A person who judges dog or cat or other animal shows
- ✓ One who cares for horses

**Easy Turtle Racers**

*Baltimore Area Council*

**Materials Needed:** Egg Carton, permanent markers, marbles, scissors

Cut the cups from the egg carton and use markers to color them so they resemble turtles. Place a marble under each cup. Start your race at the top of a paved incline or wooden ramp and race them down the hill. Try to predict which turtle will win the race.

**Cat Grass**

*Baltimore Area Council*

Indoor cats will adore this munchable treat. Dip a pencil eraser in black paint. Stamp a paw print on a terra cotta pot. Let dry. Fill the pot with soil. Sprinkle with 1-tablespoon oat grass seed (find it at large retailers). Cover with more soil and moisten. Place the pot in a warm location and add water daily to keep soil moist. The grass will sprout in just a few days. When grass is about 4 inches tall, it's ready. Set pot by kitty's food for grazing.

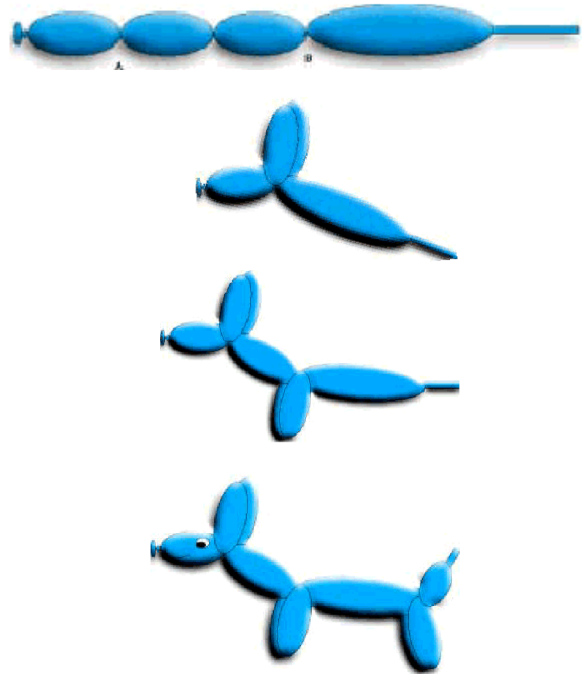

**Balloon Dog**

*Baltimore Area Council*

**Materials:** Long thin balloons (available in craft & hobby stores)

**Optional:** Hand or Foot Pump

- ✓ The first trick to making a balloon animal is to blow up the balloon. This is hard. You can buy a hand pump or use a football pump to help blow up the balloons. Do not blow the balloon up all the way. Leave the last half of the balloon unfilled. Experiment to find the proper amount.
- ✓ Carefully tie the balloon. When twisting a balloon, always start at the end with the knot. Do not worry, it will not break if you twist it, but you must hold on to both ends of the balloon. Otherwise, the balloon will untwist. The balloon will not stay twisted by itself. You have to twist the balloon together.

**Directions -**

1. Blow up the balloon half way.
2. Start at the beginning with the knot and twist a 3 to 4" bubble (or 3 or 4 fingers wide). Make sure you hang on to both ends of balloon, otherwise it will untwist. Twist it around 2 or 3 times. Do not worry it will not break. Why didn't it break? There is space at the end of the balloon for the extra air. That is why we only blow the balloon up half way.

3. While holding on to the twisted balloon, make another bubble the same size. This will be the one ear. Do not let go.
4. Make another balloon bubble the same size. This is the other ear. Look at the picture.
5. Twist balloon joints A & B together twist 2 or 4 time all the way around. The balloon will not break, and they will stay together. If yours looks like this, very good; if not, try it again -practice makes perfect!!
6. Now for the neck. Twist a 2 to 3" bubble or 3 or 4 fingers wide. This is the neck. Make sure you hang on to the balloon, both parts.
7. To make the legs, start by twisting a 2 to 3" bubble. Hang on to the neck as you twist the balloon, and do not let go of the leg.
8. Second leg, same as the first. Twist a 2 to 3" bubble. Twist those two parts together just like you did with the ears. Remember twist around each other 4 or 5 times. Twist the parts together to look like the drawing.
9. Have a lot of balloon left over? Hotdog! We make the body 1 hands long. Then twisting; make sure you hang on to the balloon. Make the back legs like you did in step 7

**Dog Biscuit Neckerchief Slides**

*Piedmont Council*

**Materials:** Small dog biscuit; Pompoms; Felt; Wiggle eyes; Seed beads; 1" long - 1/2" diameter PVC pipe

**Slide 1**

1. Cut two ears out of felt and glue on the biscuit.
2. Glue on wiggle eyes.
3. Place two 1/4" or 1/2" pompoms side by side just below the eyes.
4. Glue on a seed bead for the nose.
5. Glue on 4 small pompoms for the dog's feet.
6. If desired, fashion a collar and tag using scrap felt.

Slide 1

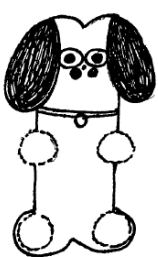

Slide 2

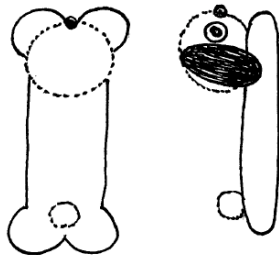

**Slide 2**

1. Fashion dog's head with wiggle eyes and felt ears.
2. Glue the head on the biscuit.
3. Glue on a pompom for a tail.

**PAGE PETS**

*Piedmont Council*

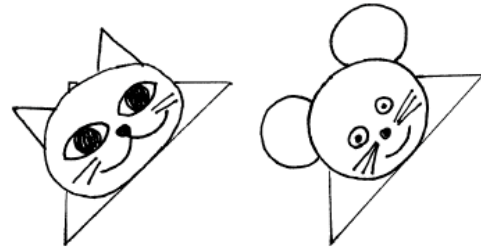

**Materials:** Used envelope; Colored paper; Marker; Scissors; Glue

1. Clip a bottom corner from an envelope, new or used.
2. Draw the head of your favorite pet on colored paper and cut it out.
3. Glue the head onto the envelope corner.
4. Add eyes, nose, mouth, ears and other features with a marker or cut from colored paper and glue on.
5. Place page pet on the corner of the page where you stopped reading.

**INVISIBLE DOG LEASH**

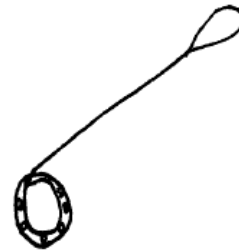

**Materials:** Wide mouth canning jar ring; Ribbon (1/4" or wider); Sturdy wire (16 gauge is stiff but is hard to work with. 19 gauge makes a less stiff leash, but is easier to use); Material to decorate the collar; Low temp glue gun

1. Cover the canning jar ring with ribbon to make a collar. Use hot glue to hold the ends of the ribbon to the ring.
2. Decorate the collar with rhinestones, glitter paints, etc.
3. Cut wire so it will extend from your hand to about 5" from the floor. Add 3" for twisting the ends under.
4. Fasten the wire to the collar by twisting it around the top and tucking the cut ends under so it can't be seen.
5. Twist the other end of the wire into a loop (for your hand) and tuck the sharp edge inside. Gently shape the wire so it curves down a bit.
6. If desired, wrap ribbon around the wire.
7. When you walk your invisible dog, hold the wire in front of you as you walk, so the dog appears to be wearing the collar.

**Bird Cookies**

*Santa Clara County Council*

Make tasty cookie treats for your feathered friends.

**Supplies:**

- 1 cup softened unsalted butter
- 3 beaten eggs
- 3 cups flour
- 1 tsp. baking soda

Pinch of salt  
Mixed birdseed

**Directions:**

1. Stir flour, baking soda, and salt together in a large bowl.
2. Add butter and eggs. Mix until well blended.
3. Roll dough out on floured surface and cut different shapes with cookie cutters.
4. Make a hole in the top of each cookie with a drinking straw.
5. Press birdseed into each side of the cookies.
6. Bake in oven at 350 degrees for 10-12 minutes.
7. After Bird Cookies have cooled, tie a ribbon or string through the hole and hang on a tree branch.

**Pencil Pup**

*Santa Clara County Council*



Supplies: (4) pinch-style wooden clothespins, Wood Glue, Felt, Googly Eyes, Pom-pom, Markers, Pencil

**Directions:**

To form the front end of the dog pinch open a clothespin and apply glue to the inner surface of the opened end. Then clamp the glued end onto a second clothespin, just behind the metal spring.

For the dog's tail end, glue and clamp together the last two clothespins so that one holds the other wide open. When the glue is dry, fit the opened end of the back half onto the lower end of the front half. Apply glue to bond the two sections.

From the felt, cut out floppy ears and circular paws. Then glue ears and paws, the googly eyes, and the pom-pom nose onto the dog.

Add spots or other distinguishing details with colored markers. Finally, pinch open the dog's mouth and insert a pencil, balancing its weight equally on both sides.

**Cup of Fish**

*Santa Clara County Council*

*I know I ran a similar item last month but it fits with this theme better. CD*



**Supplies:**

Package of blue Jell-o,  
gummy fish (or fruit-flavored sharks),  
clear plastic cups

**Directions:**

1. Make the blue Jell-o according to the directions on the box.
2. Pour into the clear plastic cups.

3. Let the cups cool about an hour in the refrigerator until partially set.
4. When the Jell-o is partially set, place a few gummy fish in each cup.  
*I would make some more Jell-o and pour it on top after putting the fish in the cups. CD*
5. Place cup back in the refrigerator until the Jell-o is completely set.
6. Eat and enjoy.

**Variations:**

- ✓ Frozen fish-popsicles (just freeze the Jell-o in popsicle molds - add the gummy fish when they are partially set - unmold very gently when entirely frozen). These are really messy to eat and are best eaten outside.
- ✓ An entire punch bowl of fish Jell-o (made like the cup o' fish)!

**AUDIENCE PARTICIPATIONS**

**Little Rabbit**

*Baltimore Area Council*

Divide the audience into 4 groups. Each group says the indicated words whenever they hear "their" word in the story.

**Little Rabbit:** "Hoppity Hop"

**Mother Rabbit:** "Oh Dear"

**Feather:** "Flutter, Flutter"

**Forest:** "Rustle, Rustle"

There was once a LITTLE RABBIT who didn't mind MOTHER RABBIT very well; and never, never told her where he was going when he went out to play. This one particular day, LITTLE RABBIT was playing just outside his house when a pretty FEATHER came floating by. Now this LITTLE RABBIT found that when he threw the FEATHER in to the air, the wind would carry it tumbling along. The poor LITTLE RABBIT completely forgot MOTHER RABBIT'S orders about not straying and kept throwing and following the FEATHER until he was deep, deep into the FOREST.

All of a sudden, LITTLE RABBIT discovered that he was lost. This part of the FOREST was strange to him. LITTLE RABBIT forgot all about his FEATHER and started running and running, trying to find his way home, Everywhere LITTLE RABBIT ran, the FOREST grew stranger and stranger. He missed MOTHER RABBIT very much. LITTLE RABBIT knew MOTHER RABBIT would be worried about him and he felt so foolish for following the FEATHER without watching how far he was going. Then LITTLE RABBIT saw a deer and asked the deer if he could tell him how to get back to his home at the edge of the FOREST. The deer could not tell him and this made LITTLE RABBIT even sadder. He wished so much that he had minded MOTHER RABBIT and not wandered into the FOREST chasing the FEATHER.

About now, though, MOTHER RABBIT was starting to search for LITTLE RABBIT. The animals along the way told MOTHER RABBIT about LITTLE RABBIT chasing a

FEATHER into the FOREST. All the animals thought he was so foolish. LITTLE RABBIT was thinking about how the sun came rising over the FOREST each morning, and disappeared over the meadow at night. So LITTLE RABBIT decided that if he followed the sun as it crossed the sky, it would lead him through the FOREST to home. As LITTLE RABBIT was running and following the sun, he thought of how foolish it was not to listen to MOTHER RABBIT. Ahead of him, LITTLE RABBIT saw MOTHER RABBIT and his heart leaped with joy; and he vowed to never disobey her again.

### THE LOST LIZARD

*Piedmont Council*

Divide Audience into four groups. Assign each group an action that goes with one of the key words. Practice the actions & noises as you are assigning groups.

CUB SCOUT: Make sign & say, "I'll do my best."

LIZARD: Slide feet on floor & say, "Scurry, scurry."

CAP: Pantomime putting on cap and say "thoomp" as the cap hits your head

COAT: Pantomime putting on coat then say, "Ziiiiip" as you zip up your coat

*Also, have the audience follow the narrator in pantomime as he tells the story*

Once there was a CUB SCOUT who had a pet LIZARD that he kept in a box. One day the CUB SCOUT looked in the box and the LIZARD was gone. "I guess I'll have to put on my CAP and COAT and look for my LIZARD," he said. So the CUB SCOUT put on his CAP and his COAT and he put the box in his COAT pocket and went outside to look for the missing LIZARD.

First, the CUB SCOUT looked under the porch (*pantomime looking under porch*). No LIZARD. Next, the CUB SCOUT looked behind a tree (*pantomime*). No LIZARD. Then the CUB SCOUT looked in the bushes (*pantomime*). No LIZARD.

Just as the CUB SCOUT was losing hope of finding his lost LIZARD, the March wind came around the corner of the house and blew the CUB SCOUT'S CAP off. Holding his COAT tightly around him, with the box in his COAT pocket, the CUB SCOUT ran down the street after his CAP (*pantomime*).

The CUB SCOUT chased his CAP past the fire hydrant to the street corner. After looking carefully both ways (*pantomime*), the CUB SCOUT ran across the street after his CAP. The wind was blowing strong, so the CUB SCOUT held his COAT tightly around him as he chased the CAP into the park.

Finally the March wind put the CAP down on a rock, and the CUB SCOUT caught up with it. And when the CUB SCOUT picked up his CAP, what do you think he saw? There on the rock, under the CAP, was his lost LIZARD! He picked up the LIZARD, put it in the box, put the box in his COAT pocket, put his CAP on his head and went straight home.

When he got inside the house, the CUB SCOUT took off his COAT and his CAP and took the LIZARD out of the box. To his surprise, he discovered that this wasn't his missing LIZARD after all. Sitting quietly on his desk, the CUB

SCOUT found his own LIZARD.

"Oh well," said the CUB SCOUT. "I'll take the new LIZARD to the den meeting this afternoon. Mrs. Smith will put him in our den zoo. Won't she be proud of me?" And with that, the CUB SCOUT put both LIZARDS in the box and went outside to play...after putting on his CAP and COAT, of course.

## ADVANCEMENT CEREMONIES

### Rover The Rescuer

*Baltimore Area Council*

**Equipment:** St. Bernard dog or any dog with small barrel around his neck, Cubmaster dressed in ski attire. Cubmaster hands out awards in "brandy barrels" made from paper tubes with plugs in ends .

*(Awards chairman runs in from side of room with dog.)*

**Cubmaster:** Rover the Rescuer has some awards for our mountain hike. (Calls out names of boys receiving Wolf and arrow points and has them come to the front.) I understand you have finished the Wolf run and for this I have something for you. (Hands out awards)

I have been told that (calls boys' names receiving Bear and arrow points and has them come forward) have mastered the Bear Ridge. We have fine awards for this great accomplishment. (Hands out awards)

Many people have been talking about the expert slope of Webelos Mountain and I would like to meet and greet these boys for their fine work. (Calls out names and has them come forward. Hands out awards)

It takes many hours of work and practice to be good at anything worthwhile and the survival of the world may someday rest with the accomplishments of these boys.

### BEST FRIENDS ADVANCEMENT

*Piedmont Council*

**Cubmaster:** You know, I think that old saying about a dog being man's best friend is true. My best friend is my dog. Asst. CM: Goldfish are nice!

**Wolf Ldr:** Not me. My best friends have been Bobcats. But now they all want to be Wolves.

**Cubmaster:** Wolves!

**Asst. CM:** I said, goldfish are nice.

**Wolf DL:** I have a list of my friends here now. They worked so hard that now their wish can come true and they will be Wolves.

**Cubmaster:** Let me see that list. Will the following Cub Scouts and their parents please step forward? (Calls out list of names)

**Cubmaster:** Having completed all the requirements and doing your best, I hereby present to you this patch and card to show that you have now become Wolves. (Presents awards and shakes hands)

**Cubmaster:** Now Wolves, please present these pins to your parents as a token of your appreciation for their support in helping you fulfill your wish.

(Hands pins to the boys, who present pins to the parents)

**Bear Ldr:** My best friends all want to become Bears.

**Cubmaster:** Bears!

**Asst. CM:** Goldfish are nice.

*(Cubmaster repeats process for Bear Scouts)*

**Webelos DL:** My best friends all want to become Webelos.

**Cubmaster:** Webelos? What kind of pet animal is a Webelos?

**Webelos DL:** A wild one.

**Asst. CM:** I still think goldfish are nice.

**Cubmaster:** (Takes list of Webelos Scouts from den leader and repeats process)

**Cubmaster:** In conclusion, this special award goes to our Assistant Cubmaster, the Friends of the Goldfish award! (Hands him a bag of Goldfish crackers)

**Asst. CM:** My favorite!

**MAN'S BEST FRIEND ADVANCEMENT IDEAS**

*Piedmont Council*

1. Attach awards to stuffed or plastic animals. If you have enough animals for the boys receiving the awards, use one toy per boy; otherwise, use one toy per group (Bobcat, Wolves, Bears). Mention the good qualities of each of the animals. Mention how these qualities are valued among friends, both humans and animals. Example: Dogs are loyal and will be there for you; Birds can sing and make you happy; Goldfish are quiet so they are good listeners!
2. If all the boys in the pack are receiving some kind of awards, prepare part of the award at the den meeting. Gather old calendars and magazines that have pictures of dogs. Ask boys to find and cutout a picture of a dog that looks like his dog, or that would be his dog if he had one. Have them glue or tape the pictures to cards. Ask them to write a few words to explain why they consider that dog their friend. Make sure to include their names. Attach their awards to the cards. At the ceremony, comment on the dog and the boy's description. Talk about the ways people make friends with dogs, other animals, and humans.

**Noah's Ark Advancement**

*Santa Clara County Council*

**Props:** Robe and walking stick for Noah (Cubmaster) and similar costume for his assistant (Awards Chair or Assistant Cubmaster). Also needed is a 1' x 6' plank to cross over into the Ark.

**Cubmaster:** Well, we finally have completed building the Ark. I'm sure glad we didn't have to build two of these. The weather shows it will only be a few hours before the rains start, so we better get busy rounding up all the animals for the trip. I must remember, though not to let the termites go with us!

**Assistant:** Noah, what animals do you want me to round up and bring aboard first?

**Cubmaster:** The first one will be the Bobcats. Will you please call them to the Ark?

**Assistant:** Will (*read names*) and their parents please come forward and cross over onto the Ark? (*Cubmaster presents awards.*)

**Cubmaster:** It's time to bring aboard the Wolves. Will you please call them to the Ark? (Repeat for Bear, Arrow Points, Webelos Badge and Activity Badges) We have certainly called aboard the most important animals to the Ark. Of course, most of you recognize them as Cub Scouts. And just like the two of each species of animals that were on Noah's Ark, Cub Scouts are famous for doing things in twos:

**CM & Asst** To do their best,  
To do their duty to God and their country,  
To help other people,  
To obey the law of the Pack.

**Assistant:** Congratulations to each Cub Scout who has earned and been presented an award tonight. We know that you have learned through your accomplishments more knowledge and character that will carry you through Boy Scouts and on to successful young men.

**Pet Show**

*Baltimore Area Council*

**Props:** Boys can be outfitted in Dog or Cat faces. Den Leaders should be dressed as Pet Trainers and the Cubmaster as the Pet Show Announcer.

**Cubmaster:** "Ladies and Gentlemen, you are about to see a parade of achievements in our Pet Show, the likes of which you have never seen before! For our 1st act, our pets with their trainers (parents) have trained and have the cunning skills like Bobcats. They have performed during their training for us showing what feats they have mastered." (Bobcats and parents come forward and go through Bobcat requirements with Cubmaster. Present badges.)

"Notice how well these skilled pets have been trained by their trainers. Let's have a fine round of applause for this fine act we have just seen performed before our very eyes."

"And now we have for our second colossal act of achievement this evening, another fine trained act. The skills of Wolves have been instilled in these pets and they are: (read names of boys receiving Wolf badge or arrow points under Wolf badge). Here come those Wolf skilled pets and their trainers: (Go through similar talk to cover some of Wolf requirements. Handle Bear badges and arrow points in same manner.)

"And now ladies and gentlemen, we have a stupendous act which takes much skill and requires work and patience as these young men climb to great heights ...in fact, to the very top in the Cub Scout parade of achievements. Let's all watch breathlessly as we give special honors in a ceremony which will demonstrate to you what heights these boys have climbed with the help of their trainers along the way. It is a privilege to introduce to you the participants in this outstanding feat." (call the boys and parents forward and



**Dog Chases Its Tail***Santa Clara County Council*

This game mimics the silliness and futility of a dog chasing its tail. You need a bandanna. Have the players line up, holding each other around the waist. (Do not allow kids to hook fingers through belts or belt loops--this results in ripped clothing and hurt fingers.) Have the last player tuck a bandanna in his pocket, or under his belt or waistband, so that it hangs down like a tail. Next, the front of the line begins to chase the end of the line, attempting to grab the bandanna. Players in the middle can help or hinder the head or the tail, depending on their whims. If the line breaks, the player who let go must step out, shortening the line.

**Poodle***Santa Clara County Council*

In this guessing game, the word "poodle" is substituted for a verb. To play, one boy picks a secret verb, then the other boys ask questions using poodle in place of the verb: "Can you poodle in a pool?" "Does poodling make you tired?" The child who correctly guesses the secret verb gets to choose the next one. Who knew verbs could be this much fun? *Or use the name of a breed of dog owned by the Den Leader or Den Chief or any member of the den.*

**Doggie Where's Your Bone***Santa Clara County Council*

It is an inside game. A boy plays the part of the dog. He sits in a chair with his back to the den. An eraser or another object is put under the chair. That is the bone. While the dog is turned around with his eyes closed someone sneaks up and steals the bone and hides it somewhere on his person. Then everyone sings: Doggy, Doggy, where's your bone? Somebody's stole it from your home. Guess who! It might be you! Then the dog has three chances to guess who took it. Sometimes it is left under his chair. If the dog guesses right then he gets to do it again. If he guesses wrong then the boy who has the bone gets a turn as the dog.

**Cats Get Your Corner***Santa Clara County Council*

You pick someone to be it. The person that is "it" gets a ball (like a standard red kickball or maybe something softer like a nerf ball). All the cats pick a corner to stand in. The den leader acts as an umpire. When everyone has a corner then the ump yells "cats get a corner". Then everyone takes off running for the corner that is next. Everyone is supposed to run in the same direction so no one should run into each other. While the cats are running, "it" tries to hit them with the ball. If you get hit you stand in the middle. The cat that never gets hit wins and becomes the next "it".

**Sheepdog***Baltimore Area Council*

This is a different form of the game "Tag." The aim of the game is for the "dogs" to round up and catch the "sheep." It starts off with one Scout trying to catch the rest. When a boy is caught he will hold hands with the other and give chase to the rest. When a third boy is caught, he will join the chain. When the fourth is caught, the four will split up into groups of two, etc. The person who is last caught is the winner.

As an alternative, the "chain" can remain unbroken to form one really long line, sweeping up the "sheep".

**Rattlesnake***Baltimore Area Council*

Arrange Cubs in a circle. Blindfold one in the center; give him a rolled newspaper. The Cubs in the circle pass and shake a tin can with pebbles in it. "It" tries to swat the Cub caught being the snake; when caught the Cub becomes "It" in the center of the circle.

**Dog Team Relay***Baltimore Area Council*

This requires a smooth tile or wood floor. One boy is to sit on a paper sack. 4-6 boys make up the dog team. The boys must first tie square knots joining several small pieces of rope to form one large one. The combined pieces should be long enough to go around the Cub dog team. Once the loop is finished, the boy on the sack holds the loop and the other boys drag him on his sack to the finish line. The first team to finish by crossing the line wins.

**I've Lost My Dog***Baltimore Area Council*

Players stand in a ring facing inwards. The leader stands in the center. He addresses one of the players, saying, "I've lost my dog." The player asks, "What is it like?" The leader describes any other person in the ring--trying also to make the description fit a dog. When the questioner guesses the identity of the person described, the one described leaves his place and is followed round the circle by the questioner. Both race in the same direction, each returning to his place. The last to get back becomes the one to whom the leader will speak when the game begins again.

**Dog And Bone***Baltimore Area Council*

One Cub is the dog and is located in the middle of the circle. The other Cubs are in a circle around the dog. An object to be the bone should be of some quiet material. As the dog hides his eyes, a Cub creeps up and quietly takes the bone back to his spot in the circle, hiding it behind his back. The dog is then told to find the bone by calling the name of the person he thinks has the bone. He gets three tries. If he doesn't guess the right person, he is still the dog. If he guesses correctly the person caught is then the dog.

**Obedience School***Baltimore Area Council*

Based on Simon Says, preface the commands with "The Trainer Says" Use appropriate dog tricks or behaviors such as lie down, beg for a treat, roll over, speak (woof), scratch your ear, wag your tail, show your tongue and pant.



## SONGS

### The Wrong End

*Santa Clara County Council*

(Tune: My Bonnie Lies Over the Ocean)

Oh, rabbits have bright, shiny noses,  
I'm telling you this as a friend.  
The reason their noses are shiny:  
The powder puff's on the wrong end.  
Wrong end – wrong end –  
The powder puff's on the wrong end –  
Wrong end –  
Wrong end – wrong end –  
The powder puff's on the wrong end!

### Bingo

*Baltimore Area Council*

There was a farmer, had a dog,  
And Bingo was his name-O  
B-I-N-G-O, B-I-N-G-O, B-I-N-G-O,  
And Bingo was his name-O.  
There was a farmer, had a dog,  
And Bingo was his name-o.  
(Clap)-I-N-G-O, (Clap)-I-N-G-O, (Clap)-I-N-G-O.  
And Bingo was his name-O.  
(Repeat. Each time replace one more letter of Bingo's name  
with a clap.)

### I Know A Cat

*Baltimore Area Council*

Sung to Bingo

I know a cat with perky ears,  
And kitty is her name-o.  
K-I-T-T-Y, K-I-T-T-Y, K-I-T-T-Y  
And kitty is her name-o  
She makes a sound and it's "meow"  
And Kitty is her name-o  
K-I-T-T-Y, K-I-T-T-Y, K-I-T-T-Y  
And kitty is her name-o

### Tom The Toad

*Baltimore Area Council*

Tune - Oh Tannenbaum

Oh Tom the Toad, Oh Tom the Toad,  
Why are you lying in the road?  
Oh Tom the Toad, Oh Tom the Toad,  
Why are you lying in the road?  
You did not see the car ahead,  
And on your head are tire treads.  
Oh Tom the Toad, Oh Tom the Toad,  
Why are you lying in the road?

Oh Matt the Rat, Oh Matt the Rat,  
Why did you tease my pussycat?  
Oh matt the Rat, Oh Matt the Rat,  
Why did you tease my pussycat?  
You used to be so brown and thin,  
And now you are inside of him.  
Oh Malt the Rat, Oh Matt the Rat,  
Why did you tease my pussycat?

Oh Jake the Snake, Oh Jake the Snake,  
How did you find my garden rake?  
Oh Jake the Snake, Oh Jake the Snake,  
How did you find my garden rake?  
You used to be so long and slick,  
And now you are so short and sick.  
Oh Jake the Snake, Oh Jack the Snake,  
How did you find my garden rake?

Oh Doug the Bug, Oh Doug the Bug,  
Why did you fall into my rug?  
Oh Doug the Bug, Oh Doug the Bug,  
Why did you fall into my rug?  
I really like to play with you,  
And now you're stuck upon my shoe.  
Oh Doug the Bug, Oh Doug the Bug,  
Why did you fall into my rug?

Oh Sid the Slug, Oh Sid the Slug,  
why are you sitting in my mug?  
Oh Sid the Slug, Oh Sid the Slug,  
Why are you sitting in my mug?  
You're sitting there, you look sublime,  
But now my mug is till of slime.  
Oh Sid the Slug, Oh Sid the Slug,  
Why are you sitting in my mug?

### How Much Is That Doggie in the Window?

*Baltimore Area Council*

(Tune: <http://www.niehs.nih.gov/kids/lyrics/howmuch.htm> )

#### Chorus:

How much is that doggie in the window? (arf! arf!)  
The one with the waggley tail  
How much is that doggie in the window? (arf! arf!)  
I do hope that doggie's for sale  
I must take a trip to California  
And leave my poor Cub Scout alone  
If he has a dog, he won't be lonesome  
And the doggie will have a good home

#### Chorus

I read in the paper there are robbers (roof! roof!)  
With flashlights that shine in the dark  
My son needs a doggie to protect him  
And scare them away with one bark (Chorus)

I don't want a bunny or a kitty  
I don't want a parrot that talks  
I don't want a bowl of little fishies  
He can't take a fish for a walk (Chorus)

#### Chorus

*Note: Arf! Arf! sounds like a small dog.  
Roof! Roof! sounds like a bigger dog.*

### I Have A Dog

*Santa Clara County Council*

(Tune: "Reuben, Reuben, I've Been Thinking")

I have a dog his name is Fido.  
I have raised him from a pup.  
He can stand upon his hind legs,  
If you hold his front legs up!

*There is a second verse to this in the Cub Scout  
Roundtable Planning Guide CD*

**Inchworm***Santa Clara County Council**There was no reference for a tune for this song in the  
SCCC Pow Wow Book. CD*

Inch worm, inch worm  
 Measuring the marigolds  
 You and your arithmetic  
 You'll probably go far  
 Inch worm, Inch worm  
 Measuring the marigolds  
 Seems to me you'd stop and see  
 How beautiful they are  
 Two and two are four  
 Four and four are eight  
 Eight and eight are sixteen  
 sixteen and sixteen are thirty-two

**The Cat Came Back***Santa Clara County Council*

Old farmer Johnson had troubles of his own  
 He had a yellow cat that wouldn't leave him alone  
 He tried and he tried to give that cat away  
 Gave him to a man going very far away

**Chorus**

But the cat came back, the very next day  
 Oh the cat came back, they thought he was a gonner  
 But the cat came back, he just couldn't stay away, away,  
 away

Gave it to a man going way out west  
 Told him to give it to the one he loved the best  
 First the train jumped the track, then it slipped the rail  
 No one is alive today to tell the sad detail

**Chorus**

Gave it to someone going up in a balloon  
 Told him to give it to the man in the moon  
 Balloon came down about 90 miles away  
 But where the pilot is today I cannot say

**Be Kind to Your Web Footed Friends***Santa Clara County Council**This is sung to the tune of Sousa's "The Stars and Stripes  
Forever" How many of you sang this each week at the end  
of "Sing Along with Mitch?" CD*

Be kind to your web-footed friends  
 For a duck may be somebody's mother  
 Who lives all alone in a swamp  
 Where it's very cold and damp  
 You might think that this is the end  
 Well it's not caus' I know another stanza  
 Be kind to your web-footed friends  
 For that cop may be Dick Tracy's brother  
 Who lives all alone on the beat  
 On a dark and dingy street  
 You might think that this is the end  
 Well, Why not!

**Boa-Constrictor***Santa Clara County Council*

I'm being swallowed by a boa-constrictor  
 I'm being swallowed by a boa-constrictor

And I don't like it one little bit  
 Oh, no, he's got my toe

*Follow up with the following verses -*

O gee, O gee, he's up to my knee  
 Oh, my, Oh, my, he's reached my thigh  
 O fiddle, O fiddle, he's at my middle  
 Oh heck, Oh heck, he's up to my neck  
 O dread, O dread, He's got my GULP!!!

**JOHNNY HAD A LITTLE DOG***Piedmont Council*

(Tune: Mary Had a Little Lamb)

Johnny had a little dog,  
 Little dog, little dog.  
 Johnny had a little dog,  
 Who's fur was bright as gold.

And everywhere that Johnny went,  
 Johnny went, Johnny went,  
 And everywhere that Johnny went,  
 The dog was sure to go.

It followed him to pack one day,  
 Pack one day, pack one day,  
 It followed him to pack one day,  
 Which was against the rules.

It made the Cub Scouts laugh and play,  
 Laugh and play, laugh and play.  
 It made the Cub Scouts laugh and play  
 To see a dog at pack.

And so the leader turned it out,  
 Turned it out, turned it out.  
 And so the leader turned it out  
 But still it lingered near.

Why does the dog love Johnny so,  
 Johnny so, Johnny so,  
 Why does the dog love Johnny so,  
 Because he is a Cub.

**WHEN THE DOGS COME RUNNIN' IN***Piedmont Council*

(Tune: When the Saints Go Marchin' In)

Oh when the dogs come runnin' in,  
 Covered with mud from toe to shin,  
 My mother gives me a mop and a bucket,  
 When the dogs come runnin' in.  
 'Cause they trample mud on floors and sheets.  
 And it would be an awesome feat,  
 If I could get them to use the door mat,  
 When the dogs come runnin' in.

**CUB GRUB****People Biscuits***Baltimore Area Council*

|                           |                          |
|---------------------------|--------------------------|
| 1 _ cup all-purpose flour | 2 teaspoon baking powder |
| L cup milk                | 1 teaspoon sugar         |
| 2 tablespoon margarine    | 1 egg                    |
| 1 teaspoon salt           | Raisins                  |
| _ cup shredded cheddar    | cheese                   |

Soften the margarine to room temperature. Mix all the ingredients except the egg with a fork to form soft dough.



4. Cut the butter into 8 equal slices. Place the butter in the flour mixture.
5. With the pastry blender, cut the butter into the dry ingredients by using a back-and-forth motion until the bits of butter-flour mixture are the size of small peas.
6. Add the buttermilk to the bowl and mix thoroughly with your hands until the mixture forms a dough. Continue to mix together until smooth.
7. Allow the dough to sit for 5 minutes.
8. Sprinkle the extra 2 tsp. flour over a clean surface. With the rolling pin, roll the dough until it is   -inch thick.
9. Cut the dough with animal cookie cutters.
10. Use the spatula to place the crackers 2 inches apart on the ungreased cookie sheet.
11. Bake the crackers for 10 to 12 minutes or until they are lightly golden brown.
12. Remove the cookie sheets from the oven using oven mitts. Let the crackers cool for 5 minutes, and then use the spatula to move them from the cookie sheets to the cooling rack.

**Brown Sugar Turtle Pralines**

*Santa Clara County Council*

A praline is a rich, pastry-shaped candy made with sugar,

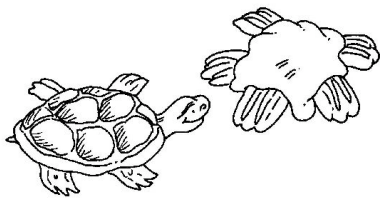

cream, butter, and pecans. Make some turtle pralines that look like your pet turtle.

**Ingredients:**

- 2 cups pecan halves
- 2 cups light brown sugar
- 1 cup light cream
- 2 Tbsp. butter

**Directions:**

*Adults need to be watching this process closely!!*

1. With a paring knife, cut    cup pecan halves into quarters by cutting each pecan horizontally into two pieces. Set aside.
2. Use the wooden spoon to combine the light brown sugar and the cream in the saucepan.
3. Bring the sugar and cream mixture to boil over a medium heat, stirring constantly.
4. Clip a candy thermometer to the side of the saucepan. Continue to cook mixture until the thermometer reads 238°F.
5. Remove the pan from the heat. Stir in the butter. Stir in the remaining    cups of pecan halves.
6. Beat the candy for 2 minutes or until it loses its shine.
7. Drop the candy by tablespoon onto waxed paper. Use the back of the spoon to shape the patties into a round shape.
8. Use the pecan quarters to decorate the candies to look like turtles. Put 2 pecan quarters at the front and 2 at the

- back for legs. Put 1 pecan quarter in between the front legs as a head.
9. Refrigerate the candy until cool, for at least 30 minutes, before serving. Makes about 24 candies.

**Bird Poop**

*Santa Clara County Council*

**Ingredients:**

- 5 cups of your favorite crunchy cereal
- 2 cups of skinny pretzels (if long, break them in half)
- 3 cups of rice crisp cereal
- 1 bag of white chocolate chips
- 2\_ cups of mini marshmallows

**Directions:**

1. Mix all the dry ingredients in a large bowl.
2. Melt the white chocolate in the microwave for about 1 minute.
3. Pour the melted chocolate over the dry ingredients and spread on wax paper to cool.
4. When your masterpiece is cool, break into chunks that look like icky bird poop.

**BANANA DOGS**

*Piedmont Council*

**Ingredients:**

- 3/4 cup peanut butter, any style
- 2 tablespoons honey
- 4 hot dog buns, split
- 2 small bananas
- 1 tablespoon lemon juice

**Directions:**

1. Put peanut butter and honey in a small bowl. Stir.
2. Spread 3 tablespoons of peanut butter-honey mixture on one hot dog bun.
3. Prepare 3 other hot dog buns the same way.
4. Peel and halve the bananas length-wise.
5. With a pastry brush, coat the 4 banana halves with lemon juice. This will help keep the banana from turning brown. Place one banana half in each hot dog bun.
6. Wrap each sandwich in clear plastic wrap.

**Cat Cookies**

*Santa Clara County Council*

**Ingredients:**

- 1 package refrigerated sugar cookie dough
- 1 Tbsp. flour



Red cinnamon candies

**Directions:**

1. Sprinkle flour on a clean, flat surface and roll out cookie dough.
2. Cut out cookies in the shape of a cat head or body using a cookie cutter.

3. Carefully transfer cookies to cookie sheet.
4. Bake according to package directions.
5. Allow the cookies to cool on the cookie sheet for about 3 minutes then press cinnamon candies in place for the eyes and nose.
6. Transfer to wire rack to continue cooling.

**Lizard Skins**

*Santa Clara County Council*

**Ingredients:**

- \_ cup Peanut butter
- 12 ounces Marshmallows
- 4 drops Green food coloring
- 16 Raisins
- 4 cups Rice Krispies; Cheerios or Corn Flakes
- Pam non-stick cooking spray

**Directions:**

1. Heat peanut butter with marshmallows in a large saucepan over low heat until melted.
2. Add green food coloring and mix in.
3. Pour in cereal and stir quickly.
4. Spray 8" pan with cooking spray then pour contents into pan.
5. Allow to cool in fridge, then cut into long thin strips, about 1" x 4".
6. Cut each raisin in half and stick on one end of each strip to make the lizard's eyes.

**STUNTS AND APPLAUSES**

**APPLAUSES & CHEERS**

*Baltimore Area Council*

**Alligator Applause:** Alligator opens his mouth very slowly, then snaps shut very fast. Both hands together start opening from fingers and palm, keeping wrists together, then snap hands together very fast. Repeat 3 times.

**Beehive:** Leader instructs everyone to start humming, when he raises his hands, the humming gets louder. When he lowers his hands, the humming gets more quiet.

**Coo-Coo Bird:** Coo-coo, coo-coo, coo-coo.

**Elephant:** Hold arms down in front of you like a trunk, putting hands flat together, lean over slightly and swing arms slowly back and forth while bringing fingers of both bands up and down saying "peanuts, peanuts."

**Mosquito:** With hand, slap yourself on the neck, arms, legs, etc.

**Seal Applause:** Extend arms, cross bands at wrist and clap several times, and make barking sounds.

**The Lost Sheep:** The leader makes an elaborate announcement introducing a soloist, who is to sing a ballad entitled "The Lost Sheep." The singer takes his position, glances to the leader who nods his head as a signal to begin. The singer then gives a plaintive "Baa-aa-aa," bows and exits the stage.

**Owls:** Cub comes on stage carrying a picture of an owl. He says, "'Owl be seen' ya!"

**Quacking Up:** Have several Scouts walk across the stage staring at the ceiling and saying "Quack, quack." Leader

then asks what they are doing and they reply, "Quacking Up!"

*Santa Clara County Council*

**Big Bear:** Stand up. Pretend to be a bear standing on his hind legs and give a great big "GROWL".

**Snake:** Put hands together above your head. While standing, slither with your body in place and say, "SSSSSSSSSSSS".

*Piedmont Council*

**CAT'S MEOW APPLAUSE:** Groups yells, "You're the cat's MeeeeOOOOOOW!!!" to a person receiving the applause.

**CAT STRETCH APPLAUSE:** Have the group start in their chairs, move hands and arms slowly upward until they are as far above their heads as possible, then stretch out their legs as far as possible, then stand and arch their backs and say "Purrrrrfect!"

**RABBIT APPLAUSE:** Place hands on head to resemble rabbit ears. Wiggle your nose and your tail. Hop three times.

**SAINT BERNARD CHEER:** Point up the mountain and yell, "To the rescue!"

**PARROT APPLAUSE:** Make wings with your arms, flap and say, "Polly wants to say, You're GREAT!"

**RUN-ONS**

*Piedmont Council*

*End each run on at your Pack meeting with "Hot Diggity Dog!"*

Cub: Mr. Pet Store owner, I want to buy a dog. How much are these puppies?

Owner: They are \$5.00 a piece.

Boy: OK, but I wanted a whole one.

Cub #1: What invention are you working on?

Cub #2: It may sound silly, but I believe it's a winner.

Cub #1: Really, what is it?

Cub #2: I've invented a dog food that tastes just like a mailman's ankle.

Emcee: We interrupt this program for a spot announcement.

Dog: (offstage):Arf, Arf, Arf!

Emcee: Thank you, Spot.

*Santa Clara County Council*

Two dogs meet each other in the park...

Dog 1: Hi, I'm Rover. What's your name?

Dog 2: I don't know, but I think it's "Down Boy."

Boy 1: Why do fire fighters use Dalmatians?

Boy 2: They use them to keep the crowds back.

Boy 3: No, they're just for good luck.

Boy 1: They use the dogs to find the fire hydrant.

Boy: Doctor, can you treat my dog?

Doctor: I would, but I'm all out of dog treats!

*Baltimore Area Council*

My dog is really smart.

How smart is he?

Every time I do something cute, he gives me a treat.



Cub #2: Invisible dog?!

Cub #1: My mom says I can have a real dog if I learn to be responsible and take care of it. I have to feed him, and walk him and just be his friend. If I do that, then my folks will take him to the vet and get all his shots.

Cub #3: So you are just practicing on a pretend dog at first?

Cub #1: I am now. The pretend elephant was just WAY too much work!

*See instructions on making a leash for an invisible dog in "Pack and Den Activities" CD*

**BONE**

*Piedmont Council*

**Scene:** All the Cubs except one are on the stage. The last Cub will enter at the end of the skit. Adjust to the size of your den.

**Cub #1:** Hey, did you hear?

**Cub #2:** No, what?

**Cub #1:** (Name of the last Cub) found a dinosaur bone in his backyard.

**Cub #3:** How do you know it was from a dinosaur?

**Cub #1:** He said it was from Rex, you know, like in Tyrannosaurus Rex.

**Cub #4:** How did he find it?

**Cub #1:** He was digging around in the yard.

**Cub #5:** Did he call the TV news people?

**Cub #2:** How big of a bone was it?

**Cub #3:** We better ask him what happened.

*(The last Cub enters)*

**Last Cub:** Hi guys, what's up?

**Cub #4:** Tell us about your bone.

**Cub #5:** Yeah. Is it from a Tyrannosaurus Rex dinosaur?

**Last Cub:** Oh, that bone. No, it wasn't from a Tyrannosaurus Rex. It was from Rex.

**Cub #1:** What other dinosaur is a Rex?

**Last Cub:** Not a dinosaur. It was my dog Rex! He sure was upset I dug up his bone!

**Three Rivers**

*From the Baloo Archives*

**Cast:** Camp Cook, 3 strangers, Three Rivers (a boy on all fours acting like a dog)

**Props:** Big Kettle or Dutch Oven

**Setting:** The camp cook is stirring the contents of the big kettle when along comes a stranger.

**1st Cub:** What's cooking? Sure does smell good.

**Cook:** Homemade stew. Want a plate?

**1st Cub:** Yeah, if it's not any trouble. Got an extra plate?

**Cook:** Sure do. Three Rivers just finished cleaning some. (The 1st Stranger picks up a plate from the pile the cook is pointing to.)

**1st Cub:** Are you sure these plates are clean?

**Cook:** "Sure are, stranger. Three Rivers just cleaned 'em.

*(This is the crux of the skit. Make sure the audience understands that Three Rivers cleaned the plates.)*

*(Two more strangers come in and get served.)*

**3rd Cub:** "Cookie, that stew was great! To show my appreciation, I'd like to clean up the dishes.

**Cook:** Never mind about that. Three Rivers will take care of them. Three Rivers!!! Three Rivers!!! Here boy, come on Three Rivers!!!"

**Three Rivers:** (Enters, barking.)

**Cubs:** (Pretend to get sick.)

**It's A ???**

*Baltimore Area Council*

**Personnel:** 4 Cubs and as many others as you wish to include in the dialog.

**Setting:** A tent is set up in the woods. It is a very dark night. Boys are inside tent. This skit could be done at a Pack outdoor activity or on stage indoors. It is easy for Cubs because most of the speaking is done inside a tent, out of sight, so lines could be read instead of memorized.

**Pete:** Hey, Ben. You all right?

**Ben:** (sleepily) Yes.

**Jim:** Why don't you guys be quiet. I'm trying to sleep.

*(A short pause - silence prevails)*

**Tom:** Hey. Pete. You all right?

**Pete:** Sure

**Ben:** Wish I had Skippy here.

**Jim:** A dog in a tent? What for?

**Ben:** To keep me warm.

**Pete:** Yeah, Keep you warm. You're scared.

**Tom:** You guys go to sleep.

*(A short pause - silence)*

**Ben:** listen! What's that noise?

**Pete:** Just the wind blowing.

**Tom:** Might be something prowling around.

**Ben:** What?

**Tom:** Oh, I don't know. A bear, maybe.

**Jim:** Or a panther.

**Ben:** A panther?

**Tom:** Yeah, or it could be a coyote!

**Pete:** A coyote?

**Jim:** Maybe it's a mountain lion.

**Ben:** Oh, no!

**Tom:** Hey, it's coming closer!

**Pete:** Where's my flashlight?

**Jim:** Look out! It's coming in the tent.

*(All yell and run out of tent. Flashlights on Ben, who is holding a toy stuffed dog or real dog)*

**All:** It's Skippy !

**Skunk In The Tent**

*Baltimore Area Council*

Cub #1: Mr. \_\_\_\_\_, Mr. \_\_\_\_\_, there's a skunk in our tent.

Cub #2: It's a real skunk!

Cub #3: What should we do?

Cubmaster: Quietly sneak up on your tent. Don't frighten the skunk. Then lay a trail of breadcrumbs from your tent leading into the forest. That should lead the skunk back into the wild. (The Cubs go do it, and return shouting. . . )

Cub #1, 2, &3: Help! Help!

Cubmaster: What's wrong? Did you go up to your tent quietly like I told you?

Cub #1, 2 & 3: Yes.

Cubmaster: Did you frighten the skunk?  
 Cub #1, 2 & 3: No.  
 Cubmaster: Did you boys lay the trail of breadcrumbs leading into the forest like I told you?  
 Cub #1, 2 & 3: Yes.  
 Cubmaster: Then what's wrong?  
 Cub #1: Well, Mr. \_\_\_\_\_, now we have TWO skunks in our tent!

**Smart Dog**

*Baltimore Area Council*

**Cast:** Tom, John, John's dog  
**Tom:** That's a nice dog you have.  
**John:** Thank you. He's nice and he's smart.  
**Dog:** Arf!  
**Tom:** A smart dog, huh? What's his name?  
**John:** Snoop.  
**Dog:** Arf!  
**Tom:** What- kind of dog is he anyway?  
**John:** A police dog.  
**Dog:** Arf  
**Tom:** A police dog? He doesn't look anything like a police dog.  
**John:** Of course he doesn't. He's a police detective in disguise!  
**Dog:** Arf!

**Puppy in the Box**

*Santa Clara County Council*

**Props:** A cardboard box with holes, cup of water inside, and a stuffed dog (or rabbit, etc.)  
**Announcer:** This scene takes place on the street outside a grocery store.  
*Several participants are gathered around outside the store, chatting.*  
**Roger:** (Enters holding the box) Hi guys, would you please hold this box for me while I go into the store? (Exits)  
**Martin:** I wonder what's in the box?  
**Gerry:** I don't know, but something is leaking out!  
**Bob:** (Rubs finger against the bottom of box, then licks finger) Hmmm, it tastes like lemon soda.  
**Martin:** (Also rubs box and tastes finger) No. I think it's more like chicken soup.

*Feel free to add in a line for everyone in your den*

**Roger:** (Returns, looks in box) Oh, you naughty puppy!

**Puppy in the Box (Version 2)**

*Santa Clara County Council*

**Cast:** Owner, 1st Pedestrian, 2 Friends, box  
**Setting:** Street Corner  
**Owner:** (Walking up to #1) Would you hold my box? I have to go into a store for a moment.  
**Cub #1:** Sure! Be glad to.  
**Cub #2:** (Walks up.) Hey! What's in the box?  
**Cub #1:** I don't know. This guy comes up to me and hands it to me. Hey! It's leaking! Maybe it's ice cream and it's melting. Let's taste it. (Taste drip) Tastes like vanilla ice cream to me!  
**Cub #2:** (Tastes it.) Chocolate it is, my friend. Hey Joe! Try this -- what does it taste like?

**Joe:** (Tastes it.) Definitely pistachio.  
**Cub #1:** Naw! It's vanilla!  
**Cub #2:** I told you, it's chocolate!  
*(Owner comes back.)*  
**Cub #1:** Mister -- what's in the box? Vanilla ice cream?  
**Cub #2:** Or chocolate?  
**Joe:** It tastes like pistachio to me!  
**Owner:** How foolish of you guys. That's my pet dog!

*I usually see these next two done as a Run Ins. CD*

**Lost Dog**

*Santa Clara County Council*

**Setting:** Dave is crying  
**Dave:** Boo hoo hoo!  
**Bob:** Hey Dave, why are you crying?  
**Dave:** (still sniffing) I lost my dog  
**Bob:** Maybe he'll come home.  
**Dave:** No, he won't come home. He's lost.  
**Bob:** Why don't you put an ad in the lost and found column of the newspaper?  
**Dave:** No. It wouldn't do any good.  
**Bob:** Well, why not?  
**Dave:** Because my dog can't read!

**Doggie Doctor**

*Santa Clara County Council*

A person comes to the psychologist and says that he needs help; he thinks that he is a dog, holding up his hands like a dog begging.  
 Throughout the skit, the person acting like a dog, does dog-like things, like scratching behind his ears, whining, etc.  
 Doctor asks how long he has had this problem.  
 Ever since he was a puppy is the reply.  
 The doctor asks if he will lie on the couch but the person says that he can't since he can't get on the furniture.  
 The doctor's advice is to make sure that he gets all his shots and doesn't go chasing any cars.

**CLOSING CEREMONIES**

*Be sure to check out the Noah's Ark closing that is in Openings to show the way to use Noah's Ark throughout the Pack Meeting. CD*

**FRIENDS--CLOSING**

*Piedmont Council*

Have each Scout make a card with a picture of his pet or selected animal. Have his part in LARGE letters on the back side of the card. Feel free to use whatever animals you want. Do not be limited by these ideas.  
**Cub # 1:** My best friend is my pet dog. I walk him, feed him, water him, and brush his fur to keep him clean. My folks take him to the vet to get his shots. He thanks me by being my friend by saying "Bow-wow-wow-wow" (Continues to bark)  
**Cub # 2:** I learn responsibility by taking care of my cat. I care for her. I like to hear her purr when I pet her. She thanks me by saying, "Meow-meow-meow" (Continues to meow)



**Cub # 3:** I care for my friend, the snake. I keep him in his cage and watch him slither around. He doesn't make much noise but when he does it sounds like "Hiss-sssss-sssss" (Continues to hiss)

**Cub # 4:** I care for my bird, and my bird is my friend. I clean his cage everyday and hear him say, "Tweet-tweet-tweet-tweet" (Continues to tweet)

**Cub # 5:** I care for my hamster. I feed him and watch him running in his wheel, squeaking like this all night long "Squeak, squeak, squeak" (Continues to squeak)

**Cubmaster:** These Cub Scouts learn to be friends by being a friend to a pet. There are many different kinds of pets out there, just like there are many different types of friends. By being kind and responsible for our pets, we learn to be kind and responsible to our friends, too.

**The Dog's Cold Nose Closing**

*Baltimore Area Council*

**Cubmaster:** Did you ever wonder why the dog has a cold nose? A man named Arthur Guiterman gives us this theory.

**Cub # 1:** When Noah, perceiving 'twas time to embark,  
Persuaded the creatures to enter the ark.  
And Noah's old dog, though long past his prime,  
Assisted in herding them. Two at a time.

**Cub # 2:** He drove in the elephants, zebras and gnus,  
Until they were packed like a box full of screws.  
The cat in the cupboard, the mouse on the shelf,  
The bug in the crack; then he backed in himself.

**Cub # 3:** But such was the lack of available space  
He couldn't tuck all of him into the place;  
So after the waters had flooded the plain  
And down from the heavens fell blankets of rain.

**Cub # 4:** He stood with his muzzle thrust out through the door  
The whole forty days of that terrible pour!  
Because of which drenching, zoologists hold,  
The nose of a healthy dog always is cold!

**Mothers Day Closing Ceremony**

*Santa Clara County Council*

I Love You, Mother  
by Joy Allison

"I love you, mother" said little John;  
Then forgetting his work, his cap went on,  
And he was off to the backyard swing,  
Leaving his mother his room to clean.

"I love you, mother" said little Phil,  
"I love you more than tongue can tell."  
Then he teased and pouted half the day  
Till his mother rejoiced when he went to play.

"I love you, mother" said little Dan.  
"Today I'll help you all I can."  
To the cradle then he did softly creep  
And rocked the baby till it fell asleep.  
Then stepping softly he took the broom  
And swept the floor and dusted the room.

Busy and happy all day was he,  
Helpful and cheerful as a boy should be.  
"I love you, mother," again they said,  
Three little boys going to bed.  
How do you think the mother guessed,  
Which of them really loved her best?

*The next one is not theme related but a classic closing - CD*

**Closing Ceremony**

*Voyageur Council*

- Cub # 1:** May I grow in character and ability as I grow in size.
- Cub # 2:** May I be honest with myself and others in what I do and say.
- Cub # 3:** May I learn and practice my religion.
- Cub # 4:** May I always honor my parents, my elders, and my leaders.
- Cub # 5:** May I develop high moral principles and the courage to live by them.
- Cub # 6:** May I strive for health in body, mind, and spirit.
- Cub # 7:** May I always respect the rights of others.
- Cub # 8:** May I set a good example so that others may enjoy and profit from my company.
- Cub # 9:** May I give honest effort to my work.
- Cub # 10:** May I regard my education as preparation for a future in life's doorway to adventure.

**Cubmaster's Minute**

**If a Dog can -**

*Voyageur Council*

With all the wonderful skills dogs can learn, there is one thing they cannot do. Dogs cannot see colors. As a matter of fact, monkeys and apes are the only animals that can see colors.

Do you ever feel like you cannot do something because you are too small, too clumsy or too young? Well next time you do, remember the dog and how he can retrieve objects, guide the blind, track lost people all without being able to distinguish colors.

**Some Dogs Are So Dog-Gone Cheerful**

[www.theceremonytable.com](http://www.theceremonytable.com)

Have you ever stopped to wonder why some dogs are so dog-gone cheerful. It's kind of pleasant, isn't it, to be around a happy dog? On the other hand, we usually try to steer clear of dogs who appear to be kind of grumpy. That's the way it is with people, too. It's much nicer to be around people who have a cheerful attitude than someone who's always looking on the dark side of things. You know, if you look for them, there are lots of reasons to be happy.

**Be sure to checkout Dave M's site for ceremonies. CD**

**Freedom**

*Baltimore Area Council*

Boys, I want to tell you a story that has a meaning. When I was a boy I had three turtles. They had a beautiful terrarium with rather low sides. They had everything they needed, except one thing... FREEDOM. Every chance they had, they would climb out.

People in many countries in this world lack the same thing - FREEDOM. But not in America. In America we have Freedom of Speech, Freedom of the Press, Freedom to go wherever we chose, the Freedom to Worship God as we wish and the Freedom to choose people to govern us.

A boy like you can grow up to be wherever he dreams of being. This is why I love America. Don't you? Good Night!

**Horizons**

*Voyageur Council*

We often speak of horizons, not one, but plural, horizons. Did it ever occur to you that there is more than one? When you have worked and planned to reach your horizon, you stop to rest and look up to see before you still another horizon just as far away as the last. When that horizon is within your grasp, wonder of wonders, still another is waiting. Few men ever reach all horizons, some never even reach the first, and still others never start. Look at what they miss. All they ever see is the small area around them. This is NOT the Cubbing way. Cub Scouts must reach a series of horizons on their climb to the Arrow of Light. Small horizons, but they lead to the farther horizons of Scouting and manhood.

**Little Things**

*Baltimore Area Council*

The other day in Colorado a great stalwart tree fell. It was nearly 800 years old, a mere sapling when Columbus landed. It had been struck by lightning 14 times; it had braved the storms of almost five centuries. It had defied earthquakes and hurricanes; it had laughed in scorn at the winter's blast and blizzards. But in the end, tiny beetles killed it. They bored under the bark, dug into its heart, and one day down come this mighty king of the forest. It is the little things that make or break us – in our business – our profession – our homes – our lives and in Scouting. Don't let the little things get you down – Keep your eye on the goal!

**WEBELOS**

A Webelos – ree !?!?!?

**What is that??**

A district or council Webelos-ree enhances the outdoor program of Webelos dens. It is a guided experience emphasizing outdoor skills for Webelos Scouts and their parents.

There is a web version of a new BIN item about this event at <http://www.scouting.org/cubscouts/resources/13-238/index.html>

Click on the links on the bottom of the page for each successive section.

A new planning guide (to replace the long dead Webelos Woods guide) will be available this spring.

**HANDYMAN  
TECHNOLOGY GROUP**

*Circle Ten Council*

This is one of the easiest and most flexible activities in the Webelos program. There are fourteen requirements from

which the den can choose a minimum of six and these can be selected on the basis of aptitude and availability.

Also, the activity can be worked for the month allocated in the Webelos calendar, or it can be done in fewer meetings, if the den meetings are prepared and organized. Some of the requirements can be used for den meeting fillers, if you exhaust a topic early or some of the resources you need for another activity are unavailable.

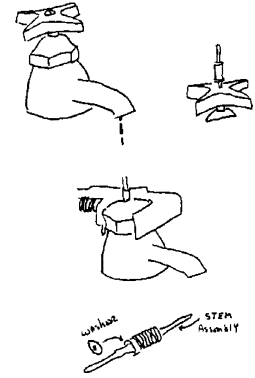

However, though Handyman is an easy topic, the den leader should handle it with care and thoroughness. Handyman allows the Scout to learn new skills and gain self-reliance and confidence in helping with activities around the house. There are also several safety and environmental issues inherent to several of the requirements.

When preparing to do Handyman, review the requirements and assess what activities you are the most comfortable with or what would be of most interest. Review them with the assistant den leader or den chief and determine which activities should be tackled and what should be rehearsed. For several activities, it may be best to divide the den into groups and work on separate requirements simultaneously. For example, while you're working on bike air pressure with three Scouts, the den chief may be covering lawn mover safety with three others – make sure the den chief is familiar with lawn mover used beforehand. Get additional help from the other den parents if needed and available.

Look over the resources you will use on the requirements. If you have two cars available, pick the one with the most accessible oil dipstick or tail light assembly. The value of the requirements is having the boys do the intended exercise, not overcoming unnecessary obstacles, which they wouldn't encounter at home.

Plan on doing more than the minimum number of requirements. The added exposure adds value, and if a Scout is shaky doing one activity, he'll have an opportunity to do other activities more confidently and feel better about earning Handyman.

**Speakers** – carpenter, electrician, plumber, car mechanic, bicycle mechanic

**Field Trips**

- Visit a local bicycle shop and talk with the mechanic to see if he will show you how to do a safety check upon your bike and perform minor adjustments.
- Visit an auto dealership.
- Arrange a visit to a service station. Have the attendant explain the use of different types of equipment (jack, torque wrench, etc.). If possible have the attendant show them how to check oil level, check fluids and belts, check tire pressure, and change light bulbs. Organize a bike rodeo.
- Visit a lumber yard or hardware store.

**Den Activities**

- At a hardware store, visit the repair shop, and acquaint the Scouts with a few specific and varied sections in the store, like electrical supplies and hand tools.
- Arrange a presentation at a well-equipped home workshop.
- Build a sawhorse.
- Arrange for a local mechanic to visit your den or visit his garage, perhaps he can show your den the safe way to change a tire, light bulb and to check the oil and transmission fluid.
- Put on a bicycle rodeo for your pack or den.
- Check with the local fire marshal or poison control center to find out how to store household cleaners and materials that will be safe from small children.
- Check the garage or storage shed in you house to ascertain the tools or implements and properly and safely stored.
- Have a clinic on the care and repair of bicycles. Set it up like a shop and have each boy bring his bike and do repairs, etc.
- Have Webelos bring tools to a den meeting and demonstrate different ways to make them.
- Hold a nail-hammering contest. See who can hammer a nail in the fewest number of strokes.
- Have a family car inspection.

**Activities**

**Leaking Faucet**

A leaking faucet is usually due to a defective washer and is a problem that can easily and quickly be resolves.

- Shut off the water! If there isn't a valve under or near the sink, turn off the main supply valve.
- Unscrew cap nut of faucet.
- Using a flat wrench, unscrew nut on faucet and pull out stem assembly. (Cloth or cardboard under wrench jaws prevents scratching.)
- Remove screw on stem assembly, pry out old, worn washer, wipe out grime and put in same size new washer.
- Replace screw and reassemble faucet. Turn water on.

**Car Maintenance**

- Replace a light bulb
- Check oil level and tire pressure
- Where/how to add oil
- Where/how to add air
- Change a tire

**Equipment Needed -**

- Car - 2 spare tail or turn signal bulbs
- Tire pressure gauge
- Rags
- Oil spout
- Tire pump
- Spare tire, jack
- Wheel blocks, tire
- Wrench, rubber mallet

**Bicycle Maintenance**

Purpose - to familiarize scouts with basic bicycle maintenance and adjustments. To acquaint the scouts with the pride and satisfaction associated with being able to

personally take care of one's property; to build the can-do spirit.

- Tighten chain, adjust saddle and handle bars
- Lubricate chain crank
- Check tire pressure
- Inflate tire (empty first)
- How to determine proper tire pressure

**Equipment**

- 2 bicycles / 2 box wrenches
- Rags
- Oil can, rags
- Tire gauge
- Hand tire pump. Rags

**Every Saturday**

- Give it the air!
- Pump tires to the recommended pressure: balloon 22 to 35 lbs.; lightweight 50 lbs.; single tube 40 lbs.

**Every Memorial Day and Labor Day**

- Is your chain a daisy?
- It won't be unless you dunk it in oil, let it drain overnight, blot and apply graphite. Skip the dunk, if you are lazy, and squirt oil on the chain without taking it off the sprockets. If it crackles and squeaks, oil it more often than twice a year. A good chain should be seen, not heard. Clean and re-grease the crank bearings.'
- Don't be a pool pedaler! Squirt oil into the inner ends of the pedals. Spin them now and then.

**Light Bulb Changer**

This tool is easy to make and is very useful for mom and dad when changing those troublesome recessed light bulbs. This project can also be used for a craftsman activity.

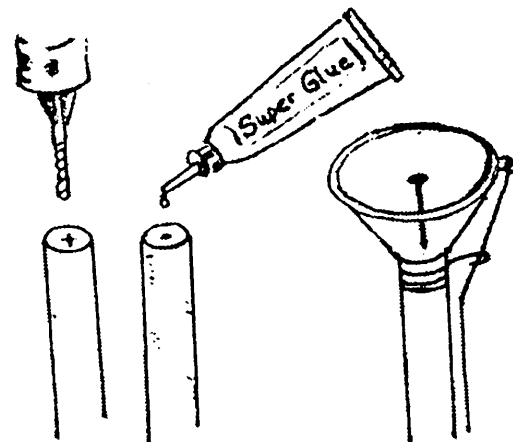

**Materials**

- 1 - 3/8" x 4" wooden dowel
- 1 - medium sized suction cup
- Super glue - one tube will complete 20 to 30 projects
- 1 - 3D box of nails
- 1 piece of string 5" long
- Drill
- 1/16" drill bit
- Hammer

1. Drill a hole 1/2" deep in the center of one end of the dowel rod. This will prevent the rod from splitting by the nail.

- Place two small drops of super glue (jelled works best) on the drilled end of the dowel rod.
- Place the small flat end of the suction cup on the glued dowel.
- Locate the center of the suction cup and align it with the drilled hole, hammer in the box nail.
- Punch a small hole in the ear of the suction cup and attach the string. This string, when pulled, will release the suction.

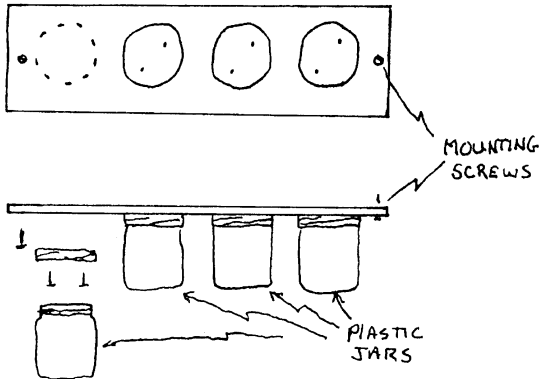

Instructions for using the light bulb changer – push suction cup on center of recessed light bulb (do not wet suction cup) and turn dowel rod counter clockwise. Remove the light bulb from the socket.

Release the suction and dispose of burned out light bulb in a safe manner. Push the suction cup on the new light bulb and screw the bulb into the socket clockwise. Pull the string to release the suction.

#### House Cleaner Storage

Cover the need to have a house cleaner's storage area. Show the den how yours is set up, and what it contains. Put together a list of the kinds of toxic cleaners and solvents typically found in a house which require safe storage, such as brass cleaner, bleach, paint thinner, etc. You may be able to provide your den with poison warning labels through your local safety department. The den could use the labels while they work on storage areas at their own homes.

#### Protect Your Tools

It cannot be said too often that tools are no better than the condition in which they are kept. Assuming you have invested your hard-earned money in a collection of top quality tools, it is only good judgment to protect your investment by adequately and safely storing your tools. In this way you not only insure the life of the tools, but also when you need one, you will know exactly where it is.

#### Portable Tool Box

This is a handy device for transporting tools wherever and whenever you need them. It can also take the place of a permanent cabinet when available storage space is limited. A tool cabinet is more desirable than a tool box when you have the space; its weight is not a matter of consideration.

#### Nail, Bolt, and Screw Organizer

This organizer will make finding screws, nails, and bolts easy. The number of containers used, is not limited to 4 but can be expanded.

#### Materials

4 plastic jars with screw-on lids  
1 pine board – 3/4" x 30"  
8 roofing nails – 7/8"  
2 drywall screws – 6 x 1 5/8"  
3/16" bit

- Lay out the lids to the jars on the board, leaving room at each end to drill a hole for the mounting screws.
- Nail the lids to the board with two nails. Two nails will prevent the lids from moving when the jars are screwed on and off.
- Drill two holes in the board, one at each end. These holes will be for the mounting screws to hold the organizer to the bottom of a shelf or bench.
- With the help of an adult, locate a spot to attach the organizer and mount the organizer with the screws.

**SAFETY NOTE** – Do not use glass jars as they may break and someone may cut themselves.

#### The How of Power Mowers

12 safety rules for users of power lawn mowers.

- Always disconnect the sparkplug wire before working on the underside of the motor or when refueling.
- Remove sticks, stones, wires or other debris from the mowing area before starting to mow.
- Never refuel indoors or when the motor is running or hot.
- Mow only when the grass is dry. Never use a power mower barefoot. Wear heavy shoes. Thousands of toes are amputated or mangled every year when feet slip under blades.
- Keep children out of your mowing area. Never let anyone get in line with the grass-throwing side of the mower while it's running.
- Never leave motor running when mower is unattended.
- Practice so you can disengage the clutch or stop motor quickly in case of an emergency.
- Never allow youngsters or inexperienced people operate the mower.
- On hills and banks cut grass sideways, not up and down.
- Stand firm behind the machine. Don't pull it backwards towards you or run with it.
- Don't use an electric power mower in the rain. Be sure its frame is grounded through the cord.
- Have your mower inspected and serviced by an experienced serviceman yearly.

#### Games for Handyman

##### Tire Inflation Game

Divide the den into two teams. Have a bicycle for each team. Each boy pumps up empty tire until he thinks it's full as judged by his feeling the hardness of the tire. The leader checks with the tire gauge to the agreed upon full tire pressure. The team with the average pressure closest to the correct full pressure wins. You think it is too easy? Add a time factor like maximum of one minute per scout.

**Traffic Matching Game**

Match the words with the correct definition.

1. Pedestrian \_\_\_\_\_
2. Breaking distance \_\_\_\_\_
3. Intersection \_\_\_\_\_
4. Hand signal \_\_\_\_\_
5. Littering \_\_\_\_\_
6. Traffic \_\_\_\_\_
7. Stop sign \_\_\_\_\_
8. Bicycle helmet \_\_\_\_\_
9. 8 to 10 seconds \_\_\_\_\_
10. Seat belt \_\_\_\_\_
11. Policeman \_\_\_\_\_
12. Accident \_\_\_\_\_
13. Traffic signal \_\_\_\_\_
14. Yellow light \_\_\_\_\_
15. Hazards \_\_\_\_\_
16. Tires, breaks, handlebars \_\_\_\_\_
17. Crosswalk \_\_\_\_\_
18. Left \_\_\_\_\_
19. Laws \_\_\_\_\_
20. Blind Spot \_\_\_\_\_

**Answers -**

- A. A place where two or more roads cross.
- B. An act in which damage, injury or death may occur.
- C. Time needed to walk across a two-lane street.
- D. A signal that alerts you to check in all directions for traffic and proceed with caution.
- E. Distance traveled from the time the brakes are applied until you stop.
- F. Items that need periodical maintenance checks.
- G. Movement of vehicles on streets, roads or highways.
- H. A person who enforces laws of the road.
- I. A designated place to cross streets.
- J. A person on foot.



- K. Places, objects or situations that could cause accidents.
- L. An electrical device that controls movement of traffic.
- M. The side of the road to be on when walking in traffic.
- N. Scattering trash in yards, streets and on the bus
- O. Regulations people live by.
- P. A sign that is red in color and has eight sides.
- Q. An area which normal field of vision fails to see.
- R. A safety device to be used by all occupants of a vehicle.
- S. Use of left arm and hand to communicate your actions to other drivers.
- T. A safety device that should be used by all bicyclists.

**Answer key** – 1-J, 2-E, 3-A, 4-S, 5-N, 6-G, 7-P, 8-T, 9-C, 10-R, 11-H, 12-B, 13-L, 14-D, 15-K, 16-F, 17-I, 18-M, 19-O, 20-Q

Handyman is a wonderful activity badge especially for the Webelos leader. After all, where else can you get your tires rotated and your oil check on your car for free! All kidding aside the Handyman activity badge deals with simple home and auto repairs along with safety at home as well as on the road. You won't find 18 different designs for stool or sawhorses in this section. What you will find are some ideas and games to help you out at your den meetings.

**Den Activities**

- Visit an Auto repair shop or your local tire store. Make arrangements ahead of time so you can visit when the shop may not be so busy.
- Take a trip to your local home center. Check with store manager before you.
- Visit a bicycle shop.
- Have a car wash day. All the adults can come and have there car washed, afterwards have snacks.
- Have a bicycle repair day. Enlist the help of several parents, be sure to have some lubricants such as WD-40 on hand ,a tube repair kit and plenty of rags.
- Check the oil level and tire pressure of parent's cars.

**Home Safety Checklist:**

Send home a checklist with the boys so they can perform a safety audit of their homes. Have them determine where their household cleaners and other hazardous materials are stored, and where tools are kept. Are these safe? Are there better or safer places these could be stored? Let the boys discuss these items with you and arrive at their own conclusions. Let them come back the next week and tell you what improvements they made to correct any problems they found.

**MARK THOSE TOOLS:**

Encourage your Webelos Scouts to avoid a similar problem by marking family lawn equipment. Try one of these techniques:

- Use enamel paint and a brush or a cotton tipped swab to letter the family's name on a place on the handle that won't set much wear.
- Wrap some colored electrician's tape around the handle in some distinctive manner.
- If you have a wood burning tool, use it to burn the family's name into a wooden handle.
- Use a ten-penny nail or a metal engraving tool to scribe the owners name into the metal.

**Super Can Crusher**

**Supplies:**

- Two 2 x 4s 18" long
- 2 1/2" hole saw
- 2 pieces of PVC
- 1" in diameter 18" long
- 1" spade bit.



1. With the spade bit, drill one hole in each end of the 2x4s. Drill \_\_\_\_\_ completely through one board and only

- 2/3rds of the way through the other. The latter will be the bottom board. The PVC pipes should slide freely through the top board, so sand the holes accordingly.
- With the hole saw, cut holes in the inside faces of the boards (bottom of the top piece top of the bottom piece) about 2 1/2" across. These should not be cut all the way through the boards. these will hold the cans.
  - Assemble the crusher, putting the bottom piece on the ground and the sliding pipes into place. Put four cans into the holes on the bottom. Slide the top board in place, hold tight to the pipes and jump on the board to crush the cans.

**Make A Five-Board Stool**

**Materials:**

- ✓ 5 boards  
Cut the top piece from a 1 "x 8", which is actually slightly thicker than 3/4" thick and 7- 5/8" wide.  
Cut the two ends from a 1" X 6" board  
Cut the rails are from two inch stock,
- ✓ Jigsaw or coping saw and a cross-cut saw,
- ✓ a drafter's compass, a T-square, a drill, finishing nails,
- ✓ white glue, and stain or paint.

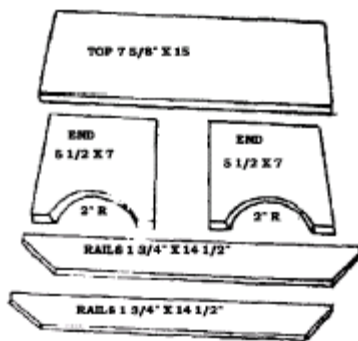

Cut pieces using a cross-cut saw for the straight cuts, and a coping saw or jigsaw for the curves in the ends. Lay out the curved lines with a compass and lay out the beveled ends on the rails with a combination square and pencil. Use the square for marking the lines for cutting the pieces to length as well. Be sure to use a sharp pencil.

After the parts are cut, trim the ends with a wood file. Sandpaper all surfaces to remove imperfections. Assemble the stool with two 2" finishing nails and white glue at each joint. To prevent splitting the wood, first drill 1/8" holes through the rails. Then drive the nails just through the rails and into the-ends to locate their position. Next drill the same size holes for the nails in the ends, apply some glue and drive in the nails.

Use a nail set to drive the heads of the nails slightly below the surface of the wood. Give your stool a final sanding and apply a coat of stain or paint.

**GAMES**

**Tool Box Sort Out:** Use an egg carton for the tool box. Have an assortment of nuts, bolts, screws, etc., to be sorted. The first boy to sort by size in the proper places in the "tool box" wins.

**Nail Driving Contest:** Give each boy a hammer and five nails. On the word "go", they are nail all five nails

completely into a round log 4 inches in diameter. First one finished is the winner.

**Board Sawing Contest:** This is the same as the nail driving contest. Give each boy a small hand saw and a 2" x 4" board. On the word "go", each boy is to saw his board in half. -

**Have A Handyman Scavenger Hunt:** Give the boys a list like the one below. Let the boys look for the items, accompanied by either a parent or leader so they don't hurt themselves. They do not have to actually physically gather the items listed, but rather write down the exact location of each.

- Pruning shears: \_\_\_\_\_
- Lawn mower: \_\_\_\_\_
- Oil can: \_\_\_\_\_
- Pliers: \_\_\_\_\_
- Nails: \_\_\_\_\_
- Air pump: \_\_\_\_\_
- Window-cleaning solution: \_\_\_\_\_
- Old newspapers: \_\_\_\_\_
- Tire pressure gauge \_\_\_\_\_
- Tire changing tool: \_\_\_\_\_
- Weed eater: \_\_\_\_\_
- Gasoline Can: \_\_\_\_\_
- File: \_\_\_\_\_
- Crescent wrench: \_\_\_\_\_
- Hammer: \_\_\_\_\_
- Screwdriver: \_\_\_\_\_

After the locations of these items are recorded, go over the list and see if any of the items are not stored in the proper locations. Also, check the tools for cleanliness and sharpness. Discuss the importance of both these with the boys.

**Name The Tools:** Cut different silhouettes of tools from construction paper, such as a hammer, plane, brace, bit, wrench, screwdriver, etc. Glue these on lightweight cardboard, and use as flashcards.

**Nail Game:** Players work in pairs for this game. Items needed: Hammers, boards, nails. Provide each team with a nail, board, and hammer. First Cub drives nail into board. Second Cub tries to pull it out with the hammer. First team to do this wins.

**Measuring Worm:** Each Cub is measured from shoulder to feet. He assumes a push-up position with elbows and knees straight. He then inches his feet as close to his hands as possible, keeping knees straight. The original position is left by inching forward with his hands, thus finding out the distance from one point to another, depending on how many times he has moved forward. The Cub with the closest measurement is the winner.

**Twenty Questions:** Each den has five minutes to write down twenty things it takes to make a house. Not what is In a house after it is built, but what it takes to make it. The den that gets 20 things written down first is the winner.

## OUTDOORSMAN OUTDOOR GROUP

*Circle Ten Council*

The best way to work on the Outdoorsman Activity Badge is at a Parent-Son overnight campout like a Webelos Overnighter. Policies of the Boy Scouts of America encourage Parent-Son overnights during the Webelos years. This is not a full-fledged Boy Scout campout – only a taste of what is to come when the boy joins a troop. After a Cub Scout becomes a Boy Scout, he will become proficient in handling himself in the woods. As a Webelos Scout, he should not be expected to master any of these skills – only to have a little fun in the woods.

Your activities on the Outdoorsman badge should all point towards the Parent-Son campout. If you are working on this badge in the spring or summer, you might dispense with the regular den meetings and concentrate on outdoor activities such as cooking practice, fire building and safety and hiking.

### Den Activities

- ✓ Make a tent.
- ✓ Make a den First Aid Kit.
- ✓ Have a den cookout.
- ✓ Learn aluminum foil cooking techniques.
- ✓ Have a campout planning session with the boys. Make a list of items you will need for backyard camping and for Parent-Son overnight.
- ✓ Practice camping in the backyard.
- ✓ Show boys how to make an improvised sleeping bag or bed.
- ✓ Make sure they are familiar with fire safety principles, which include no flame lights in tents or liquid fire starters.
- ✓ Go on a Parent-Son campout.
- ✓ Make simple tools for den outings.



### Ideas for Pack Meeting

- ✓ Exhibit – homemade tent, first aid kit, improvised sleeping bag, posters or chats on safety
- ✓ Demonstrate – oral reports from Parent-Son overnight campout, show how to make a tent or a sleeping bag, explain the contents of a first aid kit.

### What to do when lost in the woods:

- ✓ A clear head will find itself. If everyone remembered this, there would be fewer reports of persons lost in the mountains and forests, according to the United States forest service rangers.
- ✓ Merely being out of sight of others in a strange forest give many a man the creeps – a natural feeling but a dangerous one. Never yield to it. In the mountains the grip of panic is too often the grip of death.
- ✓ “Finding oneself when lost is the test of a man,” says a veteran of the Forest Service who has seen men, women

and even children save themselves by sheer pluck and presence of mind. Loss of mental control is more serious than the lack of food, water, or clothing or the possible proximity of wild animals. The man who keeps his head has the best chance to come through in safety.



### The following helpful rules are worth remembering:

1. Stop, sit down, and try to figure out where you are. Use your head, not your legs.
2. If caught by night, fog, or a storm, stop at once and make a camp in a sheltered spot. Build a fire in a safe place. Gather plenty of dry fuel.
3. Don't wander about. Travel only downhill.
4. If injured, choose a spot on a mountain and make a signal smoke.
5. Don't yell, don't run, don't worry, and above all, don't quit.
6. If caught out toward nightfall, the traveler is urged to find a shelter quickly – a ledge, a large boulder, or a fallen tree – clear a space of ground and build a fire. If without a blanket, he may build his fire in a deep hole, cover 6 inches of hot coals with 6 inches of earth and sleep on the warmed earth. Failing fire, one should use leaves and branches to shelter himself as best as he can. A boy lost on a southern California mountain peak spent three nights safely in this manner.
7. Signal fires are the quickest way to attract attention. Build them in an open spot, cleared of all flammable material so that the fire won't spread into the forest – you don't want to burn yourself up. In the daytime throw green branches and wet wood on the blaze to make smoke. The eagle eyes of the Forest Fire lookouts or the observers in the forest patrol planes or commercial shops may spot your smoke. It is difficult for an observer in a plane to see a lone person in the forest, so the lost person must use ingenuity, and the signal smoke is the best method of attracting attention.

### Basic Knots



- ✓ Square Knot – for tightening and loosening a rope easily on guy lines.
- ✓ Tautline Hitch – for tying a rope to a post or ring; it's strong but easy to loosen.

- ✓ Clove Hitch – for tying a rope to a tree or post.
- ✓ Sheet Bend – used when you want a loop that will not slip or close up; used for rescue work.
- ✓ Bowline – for tying two ropes together and for tying bandages in first aid.
- ✓ Two Half Hitches – for tying two ropes together, especially when one is thicker than the other.

**BASIC CUB SCOUT KNOTS**

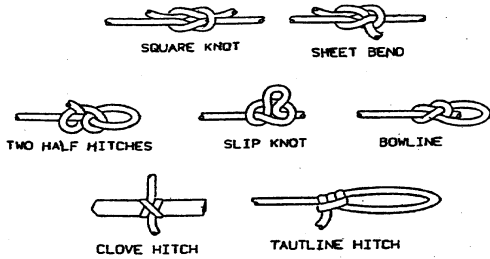

**Hand Washer**

**Materials:**

- 1 large bleach bottle or milk jug
- 1 bar of soap
- Leg of old panty hose
- String and knife
- 1 roll of paper towel
- 1 sturdy stick and small twig

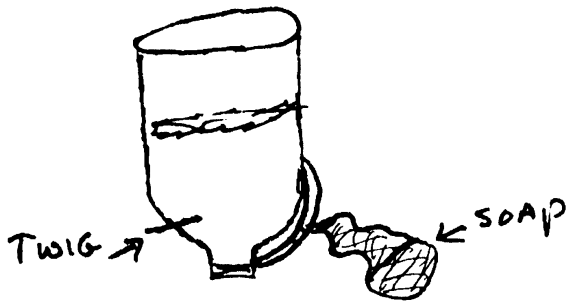

**Directions:**

- ✓ Punch a hole in each side of the bottom of the bleach bottle or milk jug. Run a string through one hole and out the other. Wrap each end of the string around the ends of a sturdy stick. [First slide a roll of paper towel onto the stick.]
- ✓ Bring ends of the string together and tie. Then hand over the tree limb.
- ✓ Slip the bar of soap into the toe of the panty hose. Tie to the handle of the bottle.
- ✓ Punch a small hole about 1 inch from the bottom and plug with a small twig. Remove twig to use. You may wish to tie the twig to the handle with the string so as not to lose it.

**Homemade Mess Kit**

Staple together two aluminum foil pie plates for thickness. Staple together two more. Use more one double thickness for top of mess kit, the other for the



bottom. Fasten together on opposite sides with paper clamp. Tie a leather shoelace through the hole in one paper lamp to make a strap to hang on your belt or bicycle handlebar.

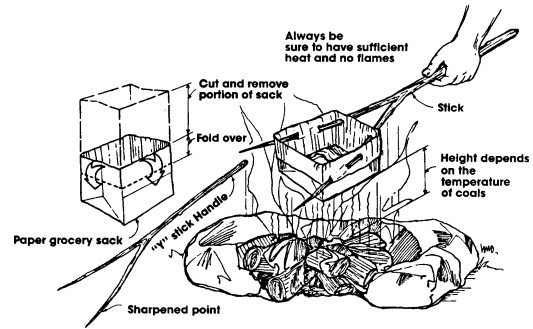

**Grocery Sack Bacon and Eggs**

Prepare and fold the brown grocery sack as shown. Be sure the sack is clean and empty. Find a suitable "handle" and make a pan, as shown. Place the bacon in the sack first. Cook the bacon, and then place your egg in the sack. Cooking time depends on the heat of the prepared coals. Be sure to have sufficient heat without flames.

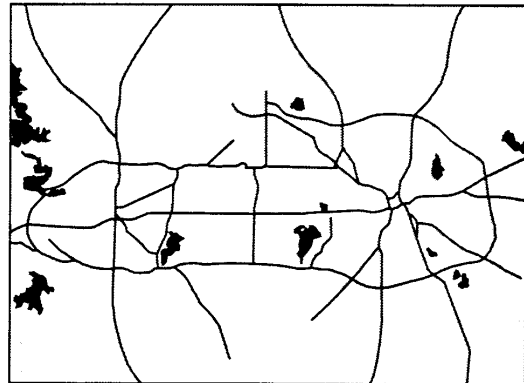

**Games**

**Map Study**

Each boy is given the same state or regional map. They are then given the names of two cities, which are located fairly far apart on the map. Using crayons, the boys try to trace as many different routes as possible that connect the two cities without duplicating a road in any of the routes. Another Study – You can use the same map to teach the boys map symbols, how to calculate mileage and other map skills.

**Map Concentration**

Let the boys make sets of map symbols on index cards and play a game of concentration.

**Nature Trailing**

Game leader clearly marks off an area no more than 20 yards in any direction from outing area. Anything beyond this area is off limits. One player sets off alone. As he walks, he scuffs up fallen leaves, bends twigs and impresses his footprints in wet or sandy spots, in order to leave a trail that others may follow. After 3 to 5 minutes, all others set out to find the trailblazer. They try to follow his trail whether individually or in groups. Meanwhile, the trailblazer hides



or returns to outing area and hides. First player to spot him is the winner.

### Roadside Observation

As hike begins, each player picks up ten small stones or pebbles, which he carries in one hand. During the hike, game leader points out some natural object – a kind of leaf, fern, or flower – without identifying it. He calls on one of the players to name the item. If the identification is correct the hiker can drop one of his pebbles. If not, the next hiker gets a chance to name the object. The game continues in this manner until one of the hikers has dropped all his pebbles.

### Clock Hike

Each boy picks a time, then, using a compass with north as 12 o'clock, you simply hike a predetermined number of paces that the "time" dictates. Then use the next boy's selected time for the new direction. This teaches a little of compass usage and provides some exposure of what they will get into in Scouts.

### Memory Hike

Take a short hike in the area near the den meeting site. While on the hike the leader points out several things of interest. Return to the meeting room and hand out pencil and paper. Have each boy list as many of the items pointed out on the hike as he can remember. The one with the most correct items wins. In larger groups the boys can work as teams, with each team compiling a list.

#### *Southern NJ Council*

Remember that the hidden word in Scouting is outing. This activity badge is one of the most important. It is a taste of what awaits the Webelos Scout when he enters Boy Scouting. Don't miss this opportunity to spend some time with your Webelos and their adult partners. The overnight camp-out takes some planning but is well worth it.

### Den Activities

- Practice tying knots
- Plan a camp-in. Find a gymnasium that will let you hold a camp-in. Introduce the envelope bed.
- Build different kinds of fires.
- Plan and hold a cook out.
- Invite someone from a bicycle club to review safety procedures
- Have a fireman discuss the necessity of a home fire safety program.

### Hug A Tree And Survive

1. Always carry a trash bag and whistle on a picnic, hike, or camping trip. By making a hole in the bag for the face and putting it on over the head, it keeps the child dry and warm. The whistle carries further than the human voice and takes less energy to use.
2. Hug a tree once you know you are lost. Hugging a tree and even talking to it calms the child down and prevents panic.
3. My parents won't be angry at me. Children have avoided searchers because they were ashamed of getting lost and afraid of punishment. If they know a happy reunion is awaiting them they will work hard to be found.

4. Make yourself big. Find your tree to hug near a small clearing if possible. Lie down when a helicopter files over. If it is cool and you are rested, make an "S.O.S." in rocks or shrubbery or by dragging your foot in the dirt.
5. There are no animals out there that can hurt you. If you hear a noise at night, yell at it. If it is an animal, it will run away. If it is a searcher, you will be found.
6. You have 200 friends looking for you. Many children who are lost do not realize that if they sit down and stay put, one of a few hundred people will find them. Some are afraid of strangers or men in uniform and do not respond to yells, and have actually hidden from searchers.
7. Foot printing your child is a five-minute exercise that cuts down the length of a search by several hours. Have the child step on a piece of aluminum foil on a soft surface such as carpeting or pillow. Mark the foil with the child name. With this print, trackers can separate your child's track from others in the area and quickly determine the direction of travel.

### Some Safety Rules For Outdoor Activities

- ✓ Always have a first aid kit handy. If possible, have an adult trained in first aid and CPR attend pack functions.
- ✓ Remember that adequate leadership and supervision help prevent accidents. Encourage boys to pair up in buddies to be aware of each other's whereabouts at all times.
- ✓ Have a plan for personal or natural emergencies (such as lightning storms, high winds etc.), which may occur during an outdoor activity. Know where emergency care can be obtained quickly. If possible, check out the location in advance for hazards.
- ✓ Avoid such dangers as buildings in disrepair or under construction, fire hazards, stinging insects, poison plants, too-rough sports or games for age and size of boys. Accidents can be prevented.
- ✓ Select a well-identified gathering place in the event the group is separated.
- ✓ Always supervise when Cub Scouts are building fires and cooking. If the den is using a ground fire, clear a space 10 feet in diameter of all burnable materials. Stay away from low hanging branches. Use of chemical or liquid must be limited to adults.

## POW WOW EXTRAVAGANZAS

*Let me know as soon as your date is set. I will post whatever I receive. I am hoping to retire in 2007 and visit lots of Pow Wows!!! CD*

Southern NJ Council

Aloha, Cub Scouts

Pow Wow in Paradise

January 21, 2006

Lakeside School, Millville, NJ

Call Southern NJ Council, 856-327-1700, extension 32, or visit the website, [www.snjscouting.org](http://www.snjscouting.org) for more information

## WEB SITES

*Santa Clara County Council*

Pets: songs, crafts, activities on pets:

[www.enchantedlearning.com/themes/pets.shtml](http://www.enchantedlearning.com/themes/pets.shtml)

Craft Site directory for Pet lovers:

[www.craftsitedirectory.com/pets](http://www.craftsitedirectory.com/pets)

American Kennel Club: [www.akc.org/](http://www.akc.org/)

Learn all about pure bred dogs and the breeds recognized by the AKC. Find a dog show in your area.

Doggie Fun: [www.doggiefun.com](http://www.doggiefun.com)

This site is a premiere resource for dog lovers. FREE contests, photo gallery, Canine Critique product testing, resources and more!

Pets Welcome: [www.petswelcome.com](http://www.petswelcome.com)

Traveling with a pet has always presented a problem, especially when you have to find a place to stay for the night. Here's a great site that has a database of hotels and motels that will accept pets. Now you AND Rover can get a good nights sleep!

PerfectPaws: [www.perfectpaws.com/pup17.html](http://www.perfectpaws.com/pup17.html)

Got a new puppy and aren't sure how to train it? Here's a nice site with general information and tips to help you.

Cat Fanciers Web Site: [www.fanciers.com](http://www.fanciers.com)

This is the site for cat fanciers. It contains information about cat breeds, colors, cat shows, the welfare of animals, and lots of other cat-related topics.

AVMA Care for Pets: [www.avma.org/care4pets](http://www.avma.org/care4pets)

The American Veterinary Medical Association offers a webpage on selecting a pet – and selecting a veterinarian to take care of it. Learn how to keep your pet healthy, discover the best way to travel with your pet, and pick up some safety tip on how to behave around animals.

Humane Society Silicon Valley: [www.hssv.org/](http://www.hssv.org/)

Great adoption stories to read about how people choose their pets. Rescue an animal. Article on Animal Behavior, dogs, cats and rabbits.

San Francisco Aquarium Society: [www.sfaquarium.org/](http://www.sfaquarium.org/)

Santa Clara Valley Canary & Exotic Bird Club:

[www.geocities.com/scvcebc/](http://www.geocities.com/scvcebc/)

Bay Area Amphibian and Reptile Society:

[www.baars.org/index\\_noflash.html](http://www.baars.org/index_noflash.html)

Free Bumper Sticker: [www.eatbiscuits.com](http://www.eatbiscuits.com)

FREE "Life is Short. Eat Biscuits!" bumper sticker. Put a little dog Zen/humor in your life with a daily "Biscuit" from The Zen of Calvin, a Dog's Guide to Living & Loving.

Purapet Free Sample:

[www.purapet.com/online/mail/5mail.asp](http://www.purapet.com/online/mail/5mail.asp)

Get a free sample from the manufacturers of the World's First Lightweight Instant Clumping Pet Litter.

Fancy Feast Free Sample: [www.fancyfeast.com](http://www.fancyfeast.com)

Register and get a coupon for a free sample of Fancy Feast cat food.

Mighty Dog® free samples:

[www.mightydog.com/index.aspx](http://www.mightydog.com/index.aspx)

Sign-up to get a free sample can of Mighty Dog® dog food.

Halo - Purely for Pets - Free Samples: [www.halopets.com](http://www.halopets.com)

Halo offers a full line of Grooming Aids, Vitamin Supplements, and Health Care Products for Cats & Dogs. Plus, Healthy all natural food for Birds. Fill out their form and get a FREE sample of either 7th Heaven Catnip or Vita Dreams Daily Greens.

IMPROVE Dog Food Supplement - Free Sample:

[www.stopitch.com](http://www.stopitch.com)

IMPROVE is a dry, granular food supplement which has been formulated to help correct your dog's skin and coat problems. Fill out their form and get a FREE taste sample.

**Kids and Dogs together**

<http://www.dog-play.com/youth.html>

**People and Pets Together**

<http://www.vetmed.wsu.edu/depts-pppp/child.asp>

**American Veterinary Medical Association**

<http://www.avma.org/>

**Canine Companions**

<http://www.caninecompanions.org/>

**Pet Information Center**

[http://www.hsus.org/programs/companion/pet\\_owners.html](http://www.hsus.org/programs/companion/pet_owners.html)

**Puppy e-cards**

<http://www.chazhound.com/postcard/posty.html>

**Toledo Humane Society Kids Page**

<http://www.toledohumanesociety.com/kids.html#puppy>

**Way cool visual illusions**

<http://www.sandlotscience.com/>

*I ran this last one last month but because USScouts.org was not fully up, I thought I would run it again CD*

**Cub Scout Achievement, Elective, Rank, and Academics and Sports Trackers on their own website!!**

*Roxanne@madsenco.com*

A lot of websites carry the Excel based trackers she developed but have old and outdated versions. So Roxanne developed her own web page that will always carry the most recent versions (with all known bugs fixed and many enhancements recommended by users).

She recently revised the Cub Scout spreadsheets to –

- ✓ Include the Outdoor Activity Award
- ✓ Make them easier to work with in OpenOffice.
- ✓ Track Tiger beads and handle up to 15 tigers.

Please direct your den leaders or advancement chairs to the website for the most recent versions of the trackers. (feel free to add a link to your pack's website if that is helpful!)

<http://www.madsenco.com/scouting.shtml>

*Thank you Roxanne!! CD*

*PS – She, also, has Girl Scout and Boy Scout Trackers!!!*

## ONE LAST THING

### A.S.A.P

Ever wonder about the abbreviation A.S.A.P.? Generally we think of it in terms of even more hurry and stress in our lives. Maybe if we think of this abbreviation in a different manner, we will begin to find a new way to deal with those rough days along the way.

\*\*\*\*\*

There's work to do, deadlines to meet;  
You've got no time to spare,  
But as you hurry and scurry-  
ASAP - ALWAYS SAY A PRAYER

In the midst of family chaos,  
"Quality time" is rare.  
Do your best; let God do the rest-  
ASAP - ALWAYS SAY A PRAYER.

It may seem like your worries  
Are more than you can bear.  
Slow down and take a breather-  
ASAP - ALWAYS SAY A PRAYER

God knows how stressful life is;  
He wants to ease our cares,  
And He'll respond to all your needs  
A.S.A.P. - ALWAYS SAY A PRAYER.

\*\*\*\*\*

**God bless and have a nice day!**